

SYLVANIA

SERVICE MANUAL

19" COLOR TELEVISION
6419CTC

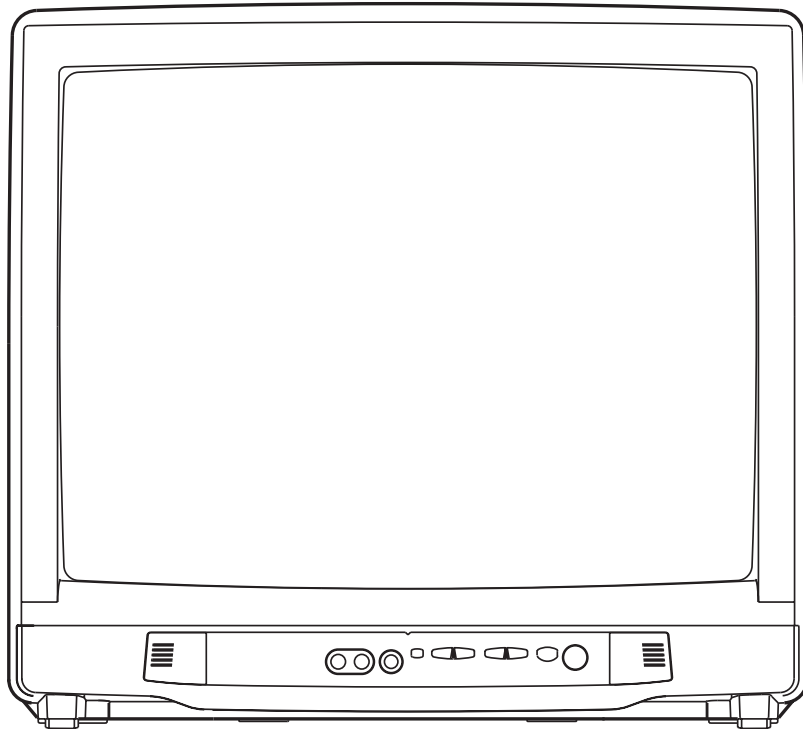

IMPORTANT SAFETY NOTICE

Proper service and repair is important to the safe, reliable operation of all Funai Equipment. The service procedures recommended by Funai and described in this service manual are effective methods of performing service operations. Some of these service special tools should be used when and as recommended.

It is important to note that this service manual contains various CAUTIONS and NOTICES which should be carefully read in order to minimize the risk of personal injury to service personnel. The possibility exists that improper service methods may damage the equipment. It also is important to understand that these CAUTIONS and NOTICES ARE NOT EXHAUSTIVE. Funai could not possibly know, evaluate and advise the service trade of all conceivable ways in which service might be done or of the possible hazardous consequences of each way. Consequently, Funai has not undertaken any such broad evaluation. Accordingly, a servicer who uses a service procedure or tool which is not recommended by Funai must first use all precautions thoroughly so that neither his safety nor the safe operation of the equipment will be jeopardized by the service method selected.

TABLE OF CONTENTS

Specifications	1-1	CBA Views and Test Points.....	7-9
Important Safety Precautions.....	2-1	Wave Forms	8-1
Standard Notes for Servicing	3-1	Wiring Diagram.....	9-1
Disassembly Instructions	4-1	IC Pin Function	10-1
Electrical Adjustment Instructions	5-1	Cabinet Exploded View	11-1
Block Diagram.....	6-1	Packing Exploded View	11-5
Schematic Diagram / CBA's and Test Points	7-1	Mechanical Parts List	12-1
Schematic Diagram	7-3	Electrical Parts List.....	13-1

SPECIFICATIONS

<TUNER>

ANT. Input ----- 75ohm Unbal., F type
 Reference Level-----20Vp-p (CRT Green Cathode)
 Test Input Signal-----400Hz 30% modulation

Description	Condition	Unit	Nominal	Limit
1. Intermediate Freq.	Picture	MHz	45.75	-
	Sound	MHz	41.25	-
2. Peak Picture Sens	VHF	dB μ v	15	30
	CATV	dB μ v	15	30
	UHF	dB μ v	15	40
3. AFT Pull In Range (10mV input)	-	MHz	\pm 2.0	\pm 0.7

<DEFLECTION>

Description	Condition	Unit	Nominal	Limit
1. Deflection Freq.	Horizontal	KHz	15.734	-
	Vertical	Hz	60	-
2. Linearity	Horizontal	%	-	\pm 15
	Vertical	%	-	\pm 10
3. Over Scan	-	%	10	-
4. High Voltage	-	KV	26	-

<VIDEO & CHROMA>

Description	Condition	Unit	Nominal	Limit
1. Misconvergence	Center	mm	-	0.4
	Side	mm	-	1.5
	Corner	mm	-	2.1
2. Brightness	APL 100%	Ft-L	40	25
3. Color Temperature	-	$^{\circ}$ K	9200 $^{\circ}$ K	-
4. Resolution	Horizontal	Line	250	-
	Vertical	Line	300	-

<AUDIO>

All items are measured across 8 Ω load at speaker output terminal.

Description	Condition	Unit	Nominal	Limit
1. Audio Output Power	10% THD	W	1	0.8
2. Audio Distortion (w/LPF)	500mW	%	2	7
3. Audio Freq. Response	-3dB	Hz	100~11K	-

Note:

Nominal specifications represent the design specifications. All units should be able to approximate these. Some will exceed and some may drop slightly below these specifications. Limit specifications represent the absolute worst condition that still might be considered acceptable. In no case should a unit fail to meet limit specifications.

IMPORTANT SAFETY PRECAUTIONS

Prior to shipment from the factory, our products are strictly inspected for recognized product safety and electrical codes of the countries in which they are to be sold. However, in order to maintain such compliance, it is equally important to implement the following precautions when a set is being serviced.

Safety Precautions for TV Circuit

1. **Before returning an instrument to the customer**, always make a safety check of the entire instrument, including, but not limited to, the following items:
 - a. Be sure that no built-in protective devices are defective and have been defeated during servicing. (1) Protective shields are provided on this chassis to protect both the technician and the customer. Correctly replace all missing protective shields, including any removed for servicing convenience. (2) When reinstalling the chassis and/or other assembly in the cabinet, be sure to put back in place all protective devices, including but not limited to, nonmetallic control knobs, insulating fishpapers, adjustment and compartment covers/shields, and isolation resistor/capacitor networks. **Do not operate this instrument or permit it to be operated without all protective devices correctly installed and functioning. Servicers who defeat safety features or fail to perform safety checks may be liable for any resulting damage.**
 - b. Be sure that there are no cabinet openings through which an adult or child might be able to insert their fingers and contact a hazardous voltage. Such openings include, but are not limited to, (1) spacing between the picture tube and the cabinet mask, (2) excessively wide cabinet ventilation slots, and (3) an improperly fitted and/or incorrectly secured cabinet back cover.
 - c. **Antenna Cold Check** - With the instrument AC plug removed from any AC source, connect an electrical jumper across the two AC plug prongs. Place the instrument AC switch in the on position. Connect one lead of an ohmmeter to the AC plug prongs tied together and touch the other ohmmeter lead in turn to each tuner antenna input exposed terminal screw and, if applicable, to the coaxial connector. If the measured resistance is less than 1.0 megohm or greater than 5.2 megohm, an abnormality exists that must be corrected before the instrument is returned to the customer. Repeat this test with the instrument AC switch in the off position.
 - d. **Leakage Current Hot Check** - With the instrument completely reassembled, plug the AC line cord directly into a 120V AC outlet. (Do not use an isolation transformer during this test.) Use a leak-

age current tester or a metering system that complies with American National Standards Institute (ANSI) C101.1 Leakage Current for Appliances and Underwriters Laboratories (UL) 1410, (50.7). With the instrument AC switch first in the on position and then in the off position, measure from a known earth ground (metal water pipe, conduit, etc.) to all exposed metal parts of the instrument (antennas, handle brackets, metal cabinet, screw heads, metallic overlays, control shafts, etc.), especially any exposed metal parts that offer an electrical return path to the chassis. Any current measured must not exceed 0.5 milli-ampere. Reverse the instrument power cord plug in the outlet and repeat the test.

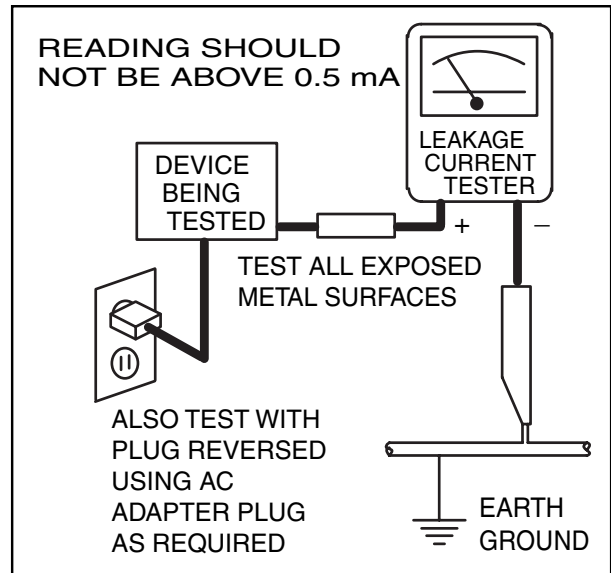

ANY MEASUREMENTS NOT WITHIN THE LIMITS SPECIFIED HEREIN INDICATE A POTENTIAL SHOCK HAZARD THAT MUST BE ELIMINATED BEFORE RETURNING THE INSTRUMENT TO THE CUSTOMER OR BEFORE CONNECTING THE ANTENNA OR ACCESSORIES.

- e. **X-Radiation and High Voltage Limits** - Because the picture tube is the primary potential source of X-radiation in solid-state TV receivers, it is specially constructed to prohibit X-radiation emissions. For continued X-radiation protection, the replacement picture tube must be the same type as the original. Also, because the picture tube shields and mounting hardware perform an X-radiation protection function, they must be correctly in place. High voltage must be measured each time servic-

ing is performed that involves B+, horizontal deflection or high voltage. Correct operation of the X-radiation protection circuits also must be reconfirmed each time they are serviced. (X-radiation protection circuits also may be called "horizontal disable" or "hold down.") Read and apply the high voltage limits and, if the chassis is so equipped, the X-radiation protection circuit specifications given on instrument labels and in the Product Safety & X-Radiation Warning note on the service data chassis schematic. High voltage is maintained within specified limits by close tolerance safety-related components/adjustments in the high-voltage circuit. If high voltage exceeds specified limits, check each component specified on the chassis schematic and take corrective action.

2. Read and comply with all caution and safety-related notes on or inside the receiver cabinet, on the receiver chassis, or on the picture tube.

3. **Design Alteration Warning** - Do not alter or add to the mechanical or electrical design of this TV receiver. Design alterations and additions, including, but not limited to circuit modifications and the addition of items such as auxiliary audio and/or video output connections, might alter the safety characteristics of this receiver and create a hazard to the user. Any design alterations or additions will void the manufacturer's warranty and may make you, the servicer, responsible for personal injury or property damage resulting therefrom.

4. **Picture Tube Implosion Protection Warning** - The picture tube in this receiver employs integral implosion protection. For continued implosion protection, replace the picture tube only with one of the same type number. Do not remove, install, or otherwise handle the picture tube in any manner without first putting on shatterproof goggles equipped with side shields. People not so equipped must be kept safely away while picture tubes are handled. Keep the picture tube away from your body. Do not handle the picture tube by its neck. Some "in-line" picture tubes are equipped with a permanently attached deflection yoke; because of potential hazard, do not try to remove such "permanently attached" yokes from the picture tube.

5. **Hot Chassis Warning** -

a. Some TV receiver chassis are electrically connected directly to one conductor of the AC power cord and maybe safety-serviced without an isolation transformer only if the AC power plug is inserted so that the chassis is connected to the ground side of the AC power source. To confirm that the AC power plug is inserted correctly, with an AC voltmeter, measure between the chassis and a known

earth ground. If a voltage reading in excess of 1.0V is obtained, remove and reinsert the AC power plug in the opposite polarity and again measure the voltage potential between the chassis and a known earth ground.

b. Some TV receiver chassis normally have 85V AC(RMS) between chassis and earth ground regardless of the AC plug polarity. This chassis can be safety-serviced only with an isolation transformer inserted in the power line between the receiver and the AC power source, for both personnel and test equipment protection.

c. Some TV receiver chassis have a secondary ground system in addition to the main chassis ground. This secondary ground system is not isolated from the AC power line. The two ground systems are electrically separated by insulation material that must not be defeated or altered.

6. Observe original lead dress. Take extra care to assure correct lead dress in the following areas:a. near sharp edges,b. near thermally hot parts-be sure that leads and components do not touch thermally hot parts,c. the AC supply,d. high voltage, ande. antenna wiring. Always inspect in all areas for pinched, out of place, or frayed wiring. Check AC power cord for damage.

7. Components, parts, and/or wiring that appear to have overheated or are otherwise damaged should be replaced with components, parts, or wiring that meet original specifications. Additionally, determine the cause of overheating and/or damage and, if necessary, take corrective action to remove any potential safety hazard.

8. **Product Safety Notice** - Some electrical and mechanical parts have special safety-related characteristics which are often not evident from visual inspection, nor can the protection they give necessarily be obtained by replacing them with components rated for higher voltage, wattage, etc.. Parts that have special safety characteristics are identified by a (▲) on schematics and in parts lists. Use of a substitute replacement that does not have the same safety characteristics as the recommended replacement part might create shock, fire, and/or other hazards. The product's safety is under reviewcontinuously and new instructions are issued whenever appropriate. Prior to shipment from the factory, our products are strictly inspected to confirm they comply with the recognized product safety and electrical codes of the countries in which they are to be sold. However, in order to maintain such compliance, it is equally important to implement the following precautions when a set is being serviced.

Precautions during Servicing

A. Parts identified by the (▲) symbol are critical for safety.

Replace only with part number specified.

B. In addition to safety, other parts and assemblies are specified for conformance with regulations applying to spurious radiation. These must also be replaced only with specified replacements.

Examples: RF converters, RF cables, noise blocking capacitors, and noise blocking filters, etc.

C. Use specified internal wiring. Note especially:

- 1) Wires covered with PVC tubing
- 2) Double insulated wires
- 3) High voltage leads

D. Use specified insulating materials for hazardous live parts. Note especially:

- 1) Insulation Tape
- 2) PVC tubing
- 3) Spacers
- 4) Insulators for transistors.

E. When replacing AC primary side components (transformers, power cord, etc.), wrap ends of wires securely about the terminals before soldering.

F. Observe that the wires do not contact heat producing parts (heatsinks, oxide metal film resistors, fusible resistors, etc.)

G. Check that replaced wires do not contact sharp edged or pointed parts.

H. When a power cord has been replaced, check that 5~6 kg of force in any direction will not loosen it.

I. Also check areas surrounding repaired locations.

J. Use care that foreign objects (screws, solder droplets, etc.) do not remain inside the set.

K. Crimp type wire connector

The power transformer uses crimp type connectors which connect the power cord and the primary side of the transformer. When replacing the transformer, follow these steps carefully and precisely to prevent shock hazards.

Replacement procedure

- 1) Remove the old connector by cutting the wires at a point close to the connector.
Important: Do not re-use a connector (discard it).
- 2) Strip about 15 mm of the insulation from the ends of the wires. If the wires are stranded, twist the strands to avoid frayed conductors.

3) Align the lengths of the wires to be connected. Insert the wires fully into the connector.

4) Use the crimping tool to crimp the metal sleeve at the center position. Be sure to crimp fully to the complete closure of the tool.

L. When connecting or disconnecting the internal connectors, first, disconnect the AC plug from the AC supply outlet.

Safety Check after Servicing

Examine the area surrounding the repaired location for damage or deterioration. Observe that screws, parts and wires have been returned to original positions. Afterwards, perform the following tests and confirm the specified values in order to verify compliance with safety standards.

1. Clearance Distance

When replacing primary circuit components, confirm specified clearance distance (d) and (d') between soldered terminals, and between terminals and surrounding metallic parts. (See Fig. 1)

Table 1 : Ratings for selected area

AC Line Voltage	Region	Clearance Distance (d) (d')
110 to 130 V	USA or CANADA	≥ 3.2 mm (0.126 inches)

Note: This table is unofficial and for reference only. Be sure to confirm the precise values.

2. Leakage Current Test

Confirm the specified (or lower) leakage current between B (earth ground, power cord plug prongs) and externally exposed accessible parts (RF terminals, antenna terminals, video and audio input and output terminals, microphone jacks, earphone jacks, etc.) is lower than or equal to the specified value in the table below.

Measuring Method : (Power ON)

Insert load Z between B (earth ground, power cord plug prongs) and exposed accessible parts. Use an AC voltmeter to measure across both terminals of load Z. See Fig. 2 and following table.

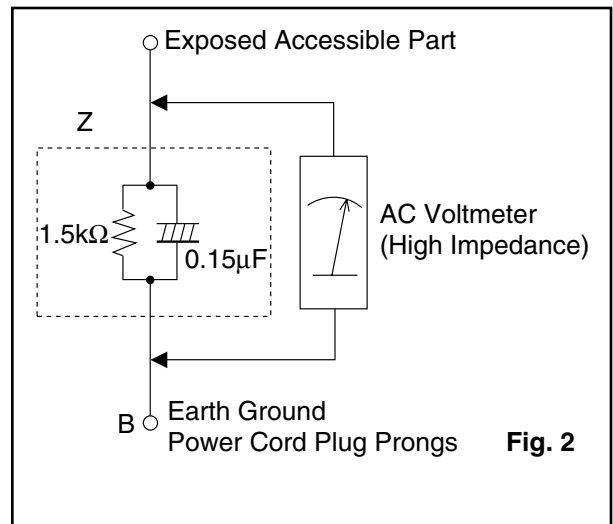
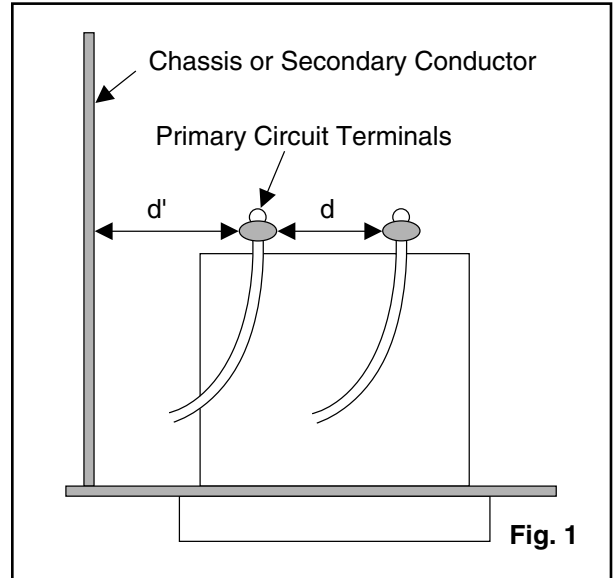

Table 2 : Leakage current ratings for selected areas

AC Line Voltage	Region	Load Z	Leakage Current (i)	Earth Ground (B) to:
110 to 130 V	USA	0.15μF CAP. & 1.5kΩ RES. connected in parallel	$i \leq 0.5$ mA rms	Exposed accessible parts

Note: This table is unofficial and for reference only. Be sure to confirm the precise values.

STANDARD NOTES FOR SERVICING

Circuit Board Indications

- a. The output pin of the 3 pin Regulator ICs is indicated as shown.

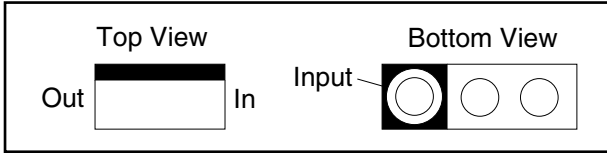

- b. For other ICs, pin 1 and every fifth pin are indicated as shown.

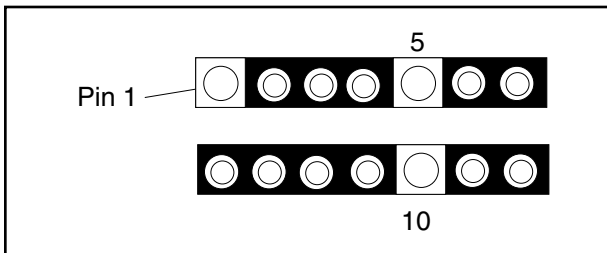

- c. The 1st pin of every male connector is indicated as shown.

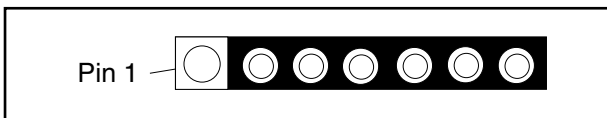

How to Remove / Install Flat Pack-IC

1. Removal

With Hot-Air Flat Pack-IC Desoldering Machine:

- (1) Prepare the hot-air flat pack-IC desoldering machine, then apply hot air to the Flat Pack-IC (about 5 to 6 seconds). (Fig. S-1-1)

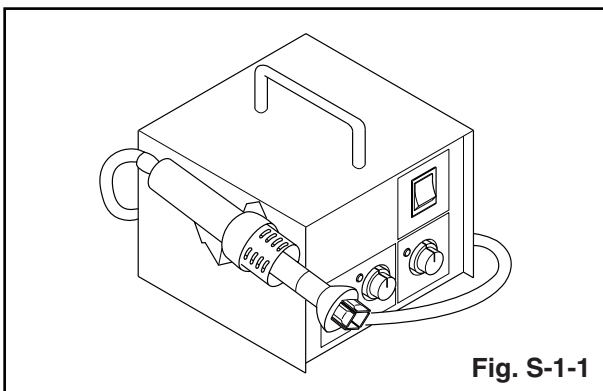

Fig. S-1-1

- (2) Remove the flat pack-IC with tweezers while applying the hot air.
- (3) Bottom of the flat pack-IC is fixed with glue to the CBA; when removing entire flat pack-IC, first apply soldering iron to center of the flat pack-IC and heat up. Then remove (glue will be melted). (Fig. S-1-6)
- (4) Release the flat pack-IC from the CBA using tweezers. (Fig. S-1-6)

Caution:

1. Do not supply hot air to the chip parts around the flat pack-IC for over 6 seconds because damage to the chip parts may occur. Put masking tape around the flat pack-IC to protect other parts from damage. (Fig. S-1-2)
2. The flat pack-IC on the CBA is affixed with glue, so be careful not to break or damage the foil of each pin or the solder lands under the IC when removing it.

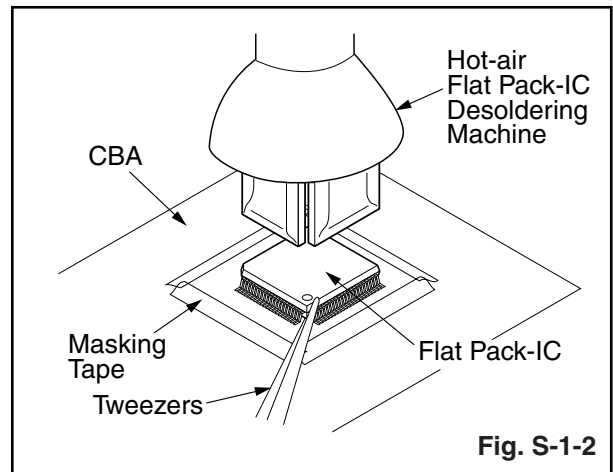
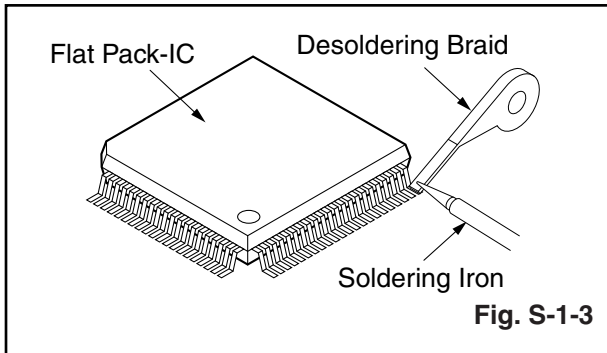

Fig. S-1-2

With Soldering Iron:

- (1) Using desoldering braid, remove the solder from all pins of the flat pack-IC. When you use solder flux which is applied to all pins of the flat pack-IC, you can remove it easily. (Fig. S-1-3)



- (2) Lift each lead of the flat pack-IC upward one by one, using a sharp pin or wire to which solder will not adhere (iron wire). When heating the pins, use a fine tip soldering iron or a hot air desoldering machine. (Fig. S-1-4)

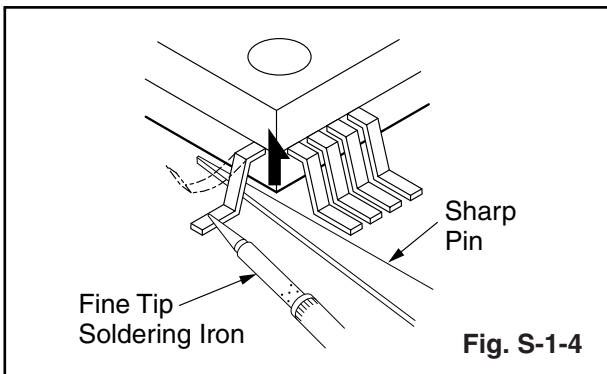

- (3) Bottom of the flat pack-IC is fixed with glue to the CBA; when removing entire flat pack-IC, first apply soldering iron to center of the flat pack-IC and heat up. Then remove (glue will be melted). (Fig. S-1-6)
- (4) Release the flat pack-IC from the CBA using tweezers. (Fig. S-1-6)

With Iron Wire:

- (1) Using desoldering braid, remove the solder from all pins of the flat pack-IC. When you use solder flux which is applied to all pins of the flat pack-IC, you can remove it easily. (Fig. S-1-3)
- (2) Affix the wire to a workbench or solid mounting point, as shown in Fig. S-1-5.
- (3) While heating the pins using a fine tip soldering iron or hot air blower, pull up the wire as the solder melts so as to lift the IC leads from the CBA contact pads as shown in Fig. S-1-5.
- (4) Bottom of the flat pack-IC is fixed with glue to the CBA; when removing entire flat pack-IC, first apply

- soldering iron to center of the flat pack-IC and heat up. Then remove (glue will be melted). (Fig. S-1-6)
- (5) Release the flat pack-IC from the CBA using tweezers. (Fig. S-1-6)

Note:

When using a soldering iron, care must be taken to ensure that the flat pack-IC is not being held by glue. When the flat pack-IC is removed from the CBA, handle it gently because it may be damaged if force is applied.

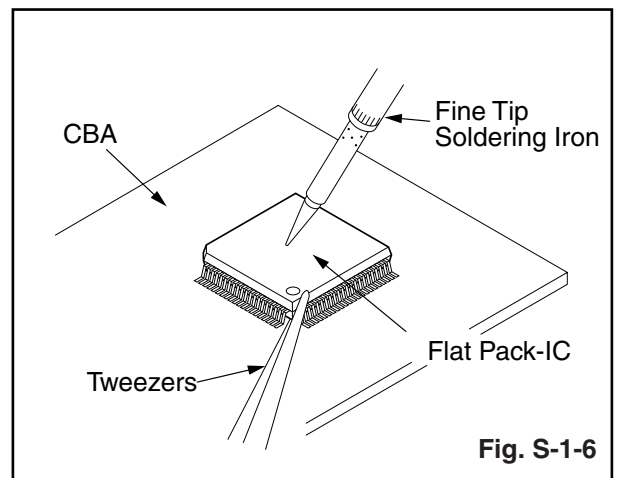
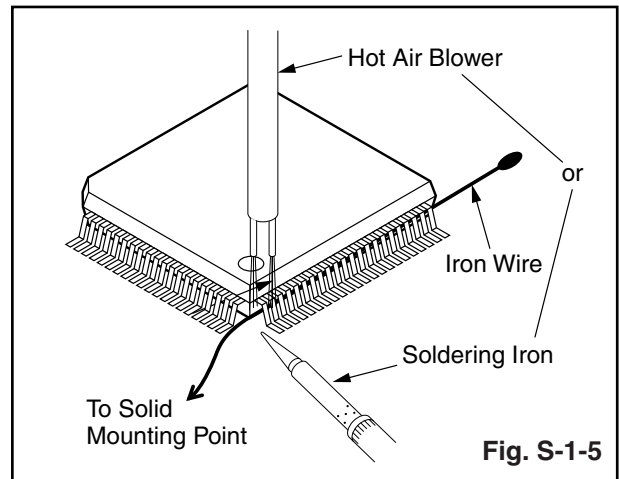

2. Installation

- (1) Using desoldering braid, remove the solder from the foil of each pin of the flat pack-IC on the CBA so you can install a replacement flat pack-IC more easily.
- (2) The "●" mark on the flat pack-IC indicates pin 1. (See Fig. S-1-7.) Be sure this mark matches the 1 on the PCB when positioning for installation. Then pre-solder the four corners of the flat pack-IC. (See Fig. S-1-8.)
- (3) Solder all pins of the flat pack-IC. Be sure that none of the pins have solder bridges.

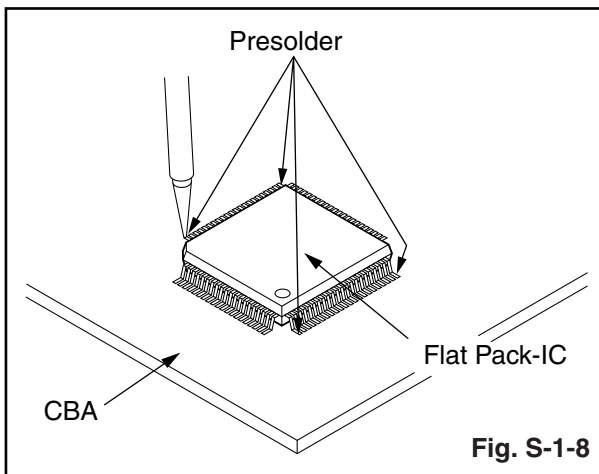
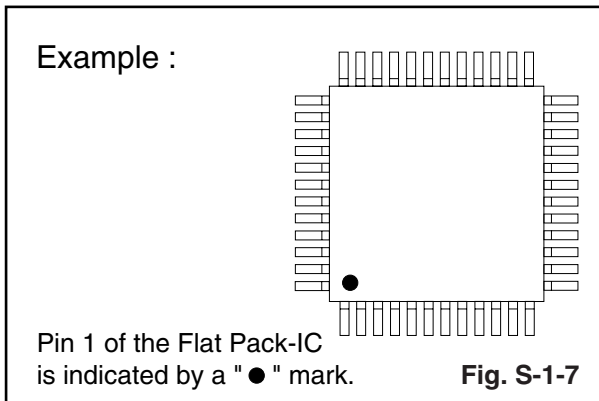

Instructions for Handling Semiconductors

Electrostatic breakdown of the semiconductors may occur due to a potential difference caused by electrostatic charge during unpacking or repair work.

1. Ground for Human Body

Be sure to wear a grounding band ($1M\Omega$) that is properly grounded to remove any static electricity that may be charged on the body.

2. Ground for Workbench

Be sure to place a conductive sheet or copper plate with proper grounding ($1M\Omega$) on the workbench or other surface, where the semiconductors are to be placed. Because the static electricity charge on clothing will not escape through the body grounding band, be careful to avoid contacting semiconductors with your clothing.

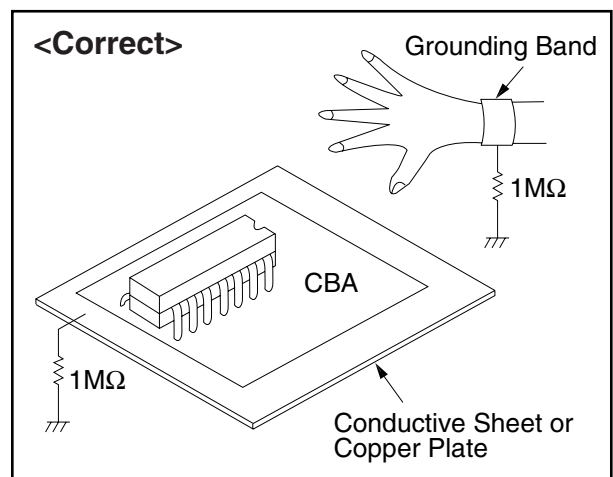
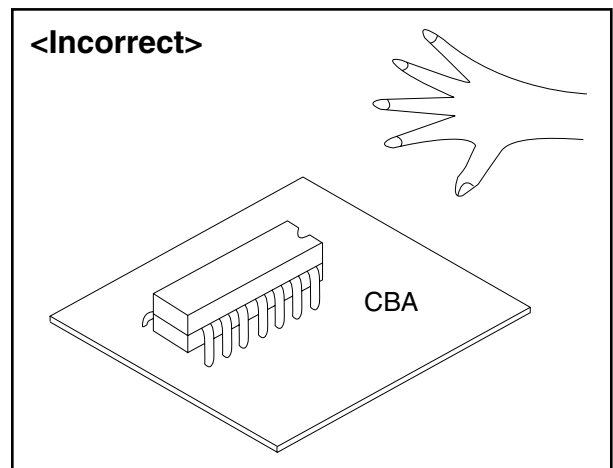

CABINET DISASSEMBLY INSTRUCTIONS

1. Disassembly Flowchart

This flowchart indicates the disassembly steps for the cabinet parts, and the CBA in order to gain access to item(s) to be serviced. When reassembling, follow the steps in reverse order. Bend, route and dress the cables as they were.

Caution !

When removing the CRT, be sure to discharge the Anode Lead of the CRT with the CRT Ground Wire before removing the Anode Cap.

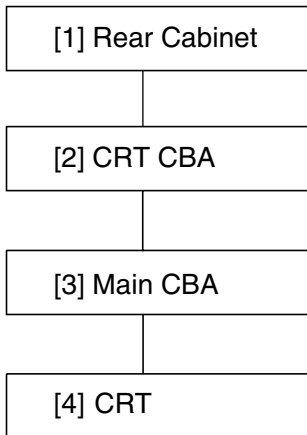

2. Disassembly Method

Step/ Loc. No.	Part	Removal		
		Fig. No	Remove/*unlock/ release/unplug/ unclamp/desolder	Note
[1]	Rear Cabinet	1,2	5(S-1), (S-3)	1
[2]	CRT CBA	4,5	CN501	2
[3]	Main CBA	3,5	CN571	3
[4]	CRT	4	4(S-2), Anode Cap	4

↓ ↓ ↓ ↓ ↓
 (1) (2) (3) (4) (5)

Note :

- (1) Order of steps in procedure. When reassembling, follow the steps in reverse order. These numbers are also used as the Identification (location) No. of parts in figures.
- (2) Parts to be removed or installed.
- (3) Fig. No. showing procedure of part location
- (4) Identification of part to be removed, unhooked, unlocked, released, unplugged, unclamped, or desoldered.
S=Screw, P=Spring, L=Locking Tab, CN=Connector, *=Unhook, Unlock, Release, Unplug, or Desolder
2(S-2) = two Screws (S-2)
- (5) Refer to the following "Reference Notes in the Table."

Reference Notes in the Table

1. Removal of the Rear Cabinet. Remove screws 5(S-1) and (S-3) then slide the Rear Cabinet backward.
2. Removal of the CRT CBA. Disconnect CN501 then pull the CRT CBA backward.
3. Removal of the Main CBA. Disconnect CN571 on the Main CBA then slide the Main CBA backward.

Caution !

Discharge the Anode Lead of the CRT with the CRT Ground Wire before removing the Anode Cap.

4. Removal of the CRT. Remove screws 4(S-2) and Anode Cap. then slide the CRT backward.

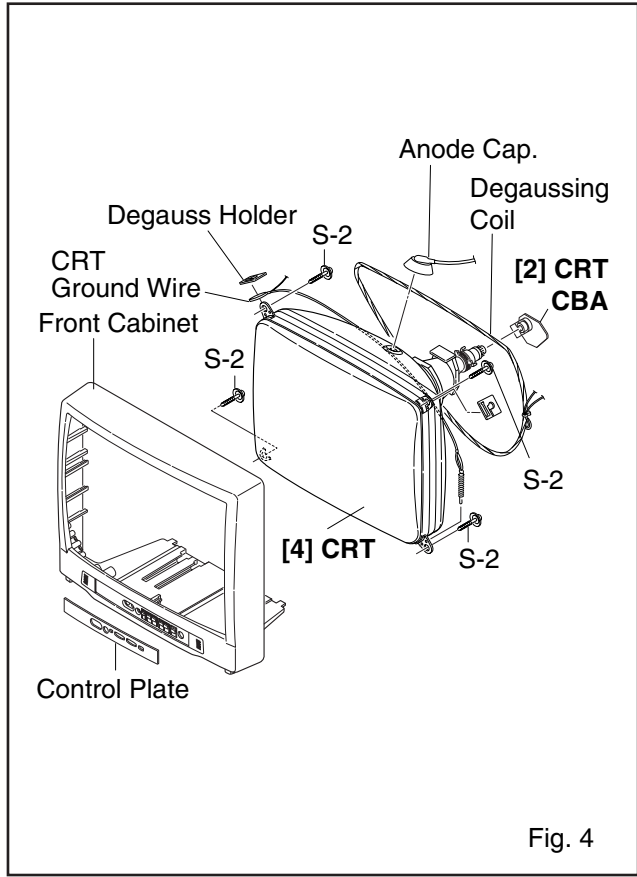
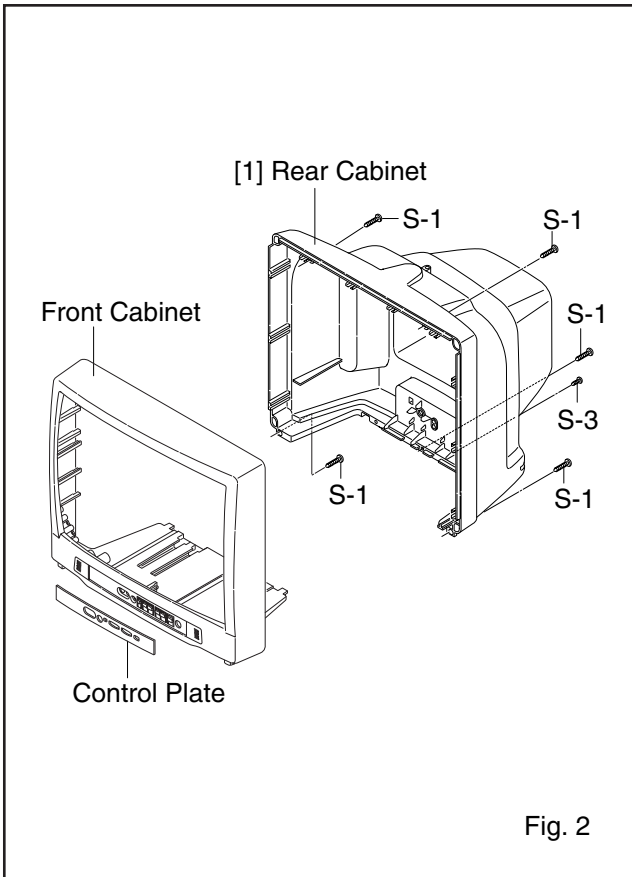
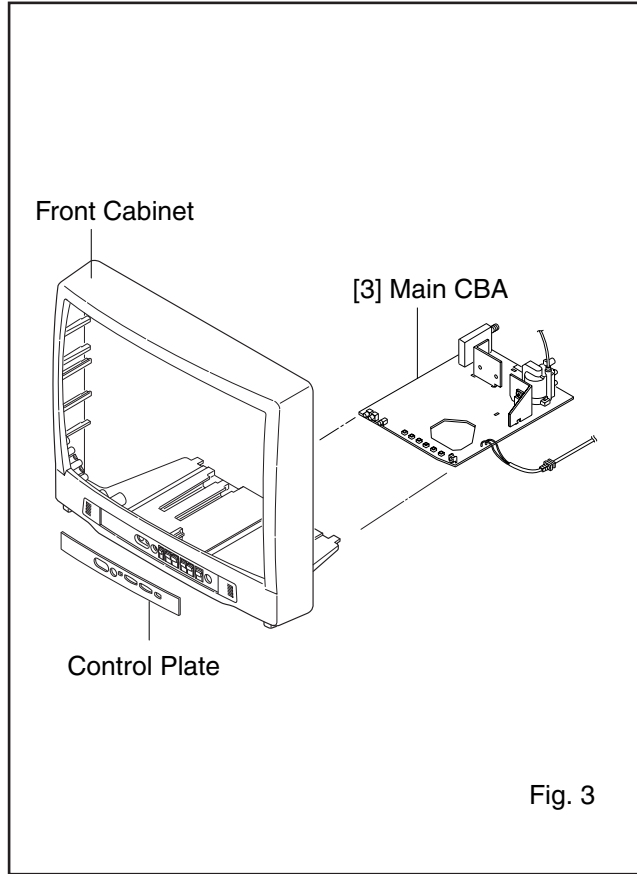
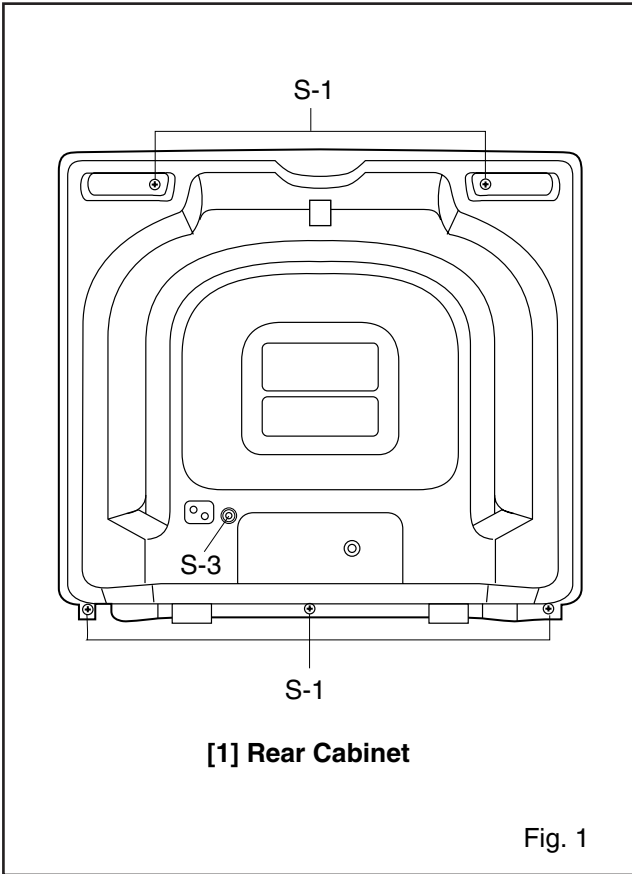

TV Cable Wiring Diagram

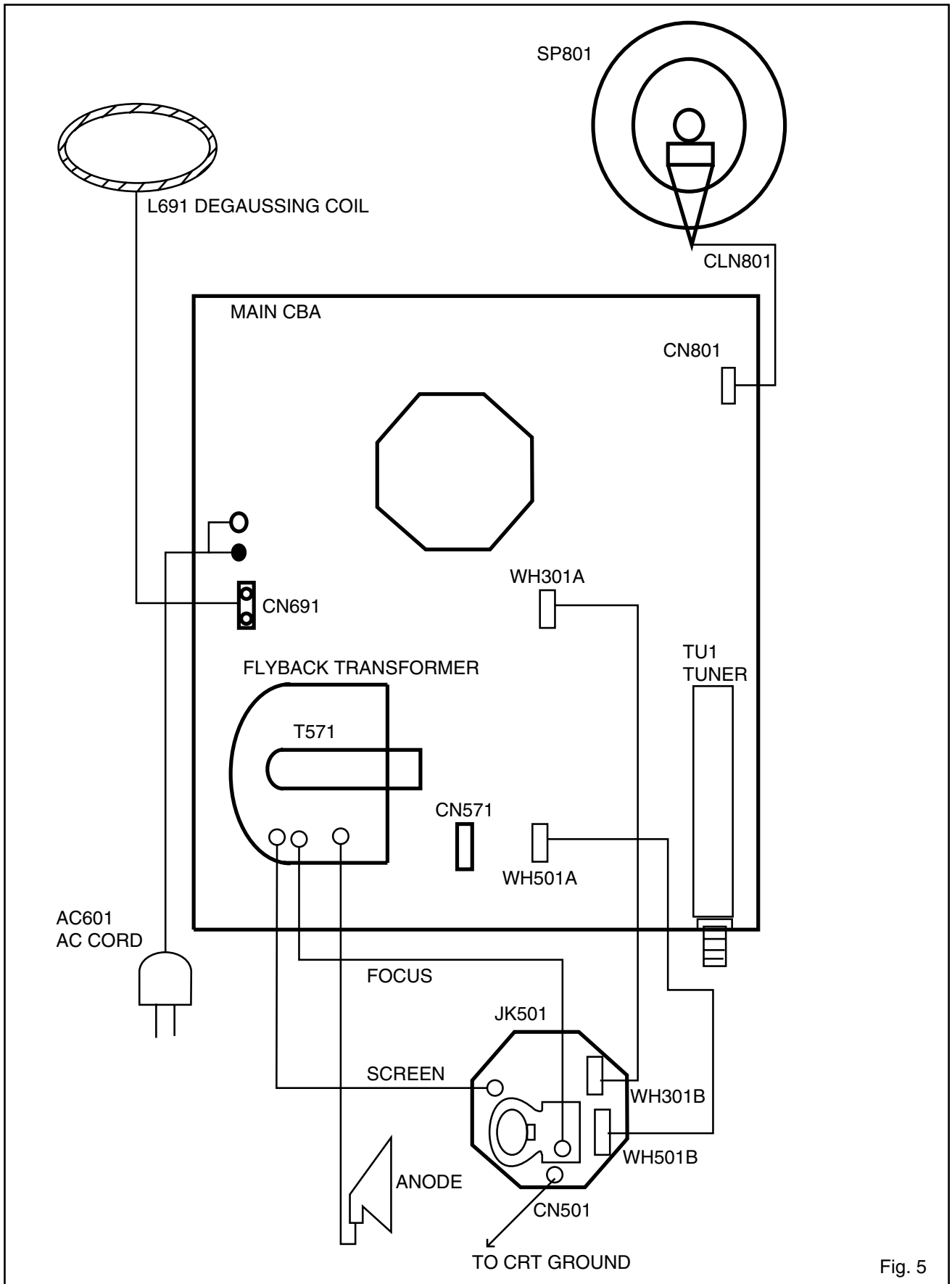

Fig. 5

ELECTRICAL ADJUSTMENT INSTRUCTIONS

General Note:

"CBA" is abbreviation for "Circuit Board Assembly".

NOTE:

Electrical adjustments are required after replacing circuit components and certain mechanical parts. It is important to perform these adjustments only after all repairs and replacements have been completed.

Also, do not attempt these adjustments unless the proper equipment is available.

Test Equipment Required

1. NTSC Pattern Generator (Color Bar W/White Window, Red Color, Dot Pattern, Gray Scale, Monoscope, Multi-Burst)
2. DC Voltmeter
3. Oscilloscope: Dual-trace with 10:1 probe, V-Range:0.001~50V/Div, F-Range:DC~AC-60MHz
4. Plastic Tip Driver
5. Remote control unit:Part No. N0121UD or N0134UD
6. DC power supply 13.2V/5A

How to make Service remote control unit:

1. Prepare normal remote control unit. (Part No. N0121UD or N0134UD) Remove 3 Screws from the back lid. (Fig. 1-1)
2. Added J1 (Jumper Wire) to the remote control CBA. (Fig. 1-2)

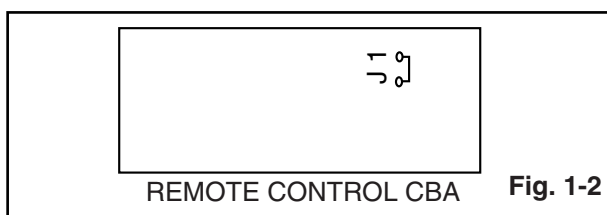
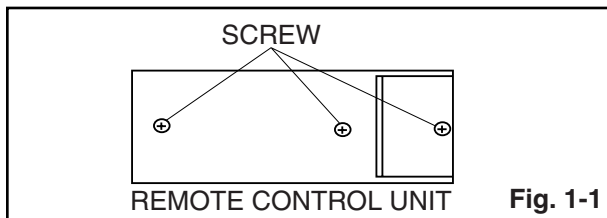

How to set up the service mode:

Service mode:

1. Use the service remote control unit.
2. Turn the power on. (Use main power on the TV unit.)
3. Press " SLEEP " button on the service remote control unit. Version of micro computer will display on the CRT. (Ex: 200-0.07 or 054-0.13)
4. Then CPU version is 054-0.13: Check the display on the lower left is "00" and if it is not "00", set it at "00" according to "3-1 FRENCH, ACCESS CODE, VIDEO TONE".

When CPU version is 200-0.07: Confirm that the character of U (U.S.A. model) is indicated on the bottom left of the CRT. If the character of C (CAN-ADA model) is indicated, perform "3-1 Setting for FRENCH data Values".

1. DC 114V Adjustment

Purpose: To obtain correct operation.

Symptom of Misadjustment: The picture is dark and the unit does not operate correctly.

Test Point	Adj. Point	Mode	Input
TP601 TP300 (GND)	VR661	---	---
Tape	M. EQ.	Spec.	
---	DC Voltmeter	+114±0.5V DC.	

Note:TP601, TP300(GND), VR661 --- Main CBA

1. Connect DC Volt Meter to TP601 and TP300(GND).
2. Adjust VR661 so that the voltage of TP601 becomes +114±0.5V DC.

2. Black Stretch Control Adjustment

Purpose: To show the fine black color.

Symptom of Misadjustment: Black color will not appear correctly.

Note: Use Service remote control unit.

1. Enter the Service mode. (See page 5-1)
2. Press " 6 " button on the Service remote control unit. " B-S " is indicated.
3. Press " CH ▲ / ▼ " buttons on the Service remote control unit so that display will change " OFF ", " 0 ", " 1 ", " 2 " and " 3 ". Then choose " B-S OFF ".
4. Press " 6 " button on the Service remote control unit. " B-S*2 " is indicated.
5. Press " CH ▲ / ▼ " buttons on the Service remote control unit so that display will change " 0 ", " 1 ", " 2 " and " 3 ". Then choose " B-S*2 0".
6. Turn the power off and on again. (Main power button on the TV unit.)

3-1. Setting for 7F and FRENCH data Values

General

1. Enter the Service mode. (See page 5-1)
2. Press " VOL ▼ " button on the Service remote control unit. Display changes " C/D ", " VCO ", " 7F ", " FRENCH ", " ACCESS CODE ", " STEREO ", " VIDEO TONE ", " FM-MODE " and " AV-OUT " cyclically when " VOL ▼ " button is pressed.

7F

1. Press " VOL ▼ " button on the Service remote control unit. Then select 7F display.
2. Press " CH ▲ / ▼ " buttons on the Service remote control unit. Then choose 7F=FF.

FRENCH

1. Press " VOL ▼ " button on the Service remote control unit. Then select FRENCH display.
2. Press " CH ▲ / ▼ " buttons on the Service remote control unit. Then choose FRENCH=ON.

When CPU version is 050-0.10, perform the following settings:

ACCESS CODE ---- set to OFF

VIDEO TONE ---- set to OFF

FM-MODE ---- set to OFF

AV-OUT ---- set to OFF

STEREO ---- set to OFF

Note: C/D and VCO data values are no need to adjust at this moment.

3-2. Setting for CONTRAST, COLOR, TINT, V-TINT and SHARP data Values

General

1. Enter the Service mode. (See page 5-1)
2. Press " MENU " button on the Service remote control unit. Display changes " BRIGHT ", " CONTRAST ", " COLOR ", " TINT ", " V-TINT " and " SHARP " cyclically when " MENU " button is pressed.

CONTRAST (CNT)

1. Press " MENU " button on the Service remote control unit. Then select " CONTRAST " (CNT) display.
2. Press " CH ▲ / ▼ " buttons on the Service remote control unit so that the value of " CONTRAST " (CNT) becomes 84.

COLOR (CLR)

1. Press " MENU " button on the Service remote control unit. Then select " COLOR " (CLR) display.
2. Press " CH ▲ / ▼ " buttons on the Service remote control unit so that the value of " COLOR " (CLR) becomes 66.

TINT (TNT)

1. Press " MENU " button on the Service remote control unit. Then select " TINT " (TNT) display.
2. Press " CH ▲ / ▼ " buttons on the Service remote control unit so that the value of " TINT " (TNT) becomes 60.

V-TINT (V-TNT)

1. Press " MENU " button on the Service remote control unit. Then select " V-TINT " (V-TNT) display.
2. Press " CH ▲ / ▼ " buttons on the Service remote control unit so that the value of " V-TINT " (V-TNT) becomes 62.

SHARP (SHARP)

1. Press " MENU " button on the Service remote control unit. Then select " SHARP " (SHARP) display.
2. Press " CH ▲ / ▼ " buttons on the Service remote control unit and select " SHARP OFF ".

Note: BRIGHT data value is no need to adjust at this moment.

4. H f₀ Adjustment

Purpose: To get correct horizontal frequency.

Symptom of Misadjustment: . If H f₀ adjustment is in correct, sqew distortion will appear on the screen.

Test Point	Adj. Point	Mode	Input
R583	CH ▲ / ▼ button ["H-ADJ"] MODE		---
Tape	M. EQ.	Spec.	
---	Frequency Counter	15.734kHz±300Hz	

Note: R583 --- Main CBA

Use Service remote control unit.

1. Connect Frequency Counter to R583 and ground.
2. Set the unit to the VIDEO mode which is located before CH2 and no input is necessary. Enter the Service mode. (See Page 5-1)
3. Operate the unit for at least 20 minutes.
4. Press " 2 " button on the Service remote control unit and select H-ADJ Mode. (By pressing " 2 " button the display will change from TV AGC to H-ADJ)
5. Press " CH ▲ / ▼ " button on the Service remote control unit so that the display will change " 0 " ~ " 7 ". At this moment, Choose display one of them from " 0 " ~ " 7 " when the Frequency Counter shows 15.734 kHz±300Hz or closer.
6. Turn the power off and on again. (Main Power button on the TV unit.)

5. VCO Adjustment

Purpose: To operate VCO correctly.

Symptom of Misadjustment: VCO does not work correctly and/or synchronization is faulty.

Test Point	Adj. Point	Mode	Input
---	---		No signal
Tape	M. EQ.	Spec.	
---	---	---	

Note: Use service remote control unit.

1. Disconnect the RF input and set the unit to Channel 4.
2. Enter the Service mode. (See Page 5-1)
3. Press " 3 " button on the Service remote control unit. The Auto VCO adjustment is started.
4. If the display color is changed from red to green, This adjustment is done.
5. Turn the Power off and on again. (Main power button on the TV unit.)

6. AGC Adjustment

Purpose: Set AGC (Auto Gain Control) Level.

Symptom of Misadjustment: AGC does not synchronize correctly when RF input level is too weak and picture distortion may occur if it is too strong.

Test Point	Adj. Point	Mode	Input
TP301	CH ▲ / ▼ buttons	RF	Color Bar 67.25MHz 60dBμV
Tape	M. EQ.	Spec.	
---	Pattern Generator DC Volt Meter	+2.5±0.1VDC or +2.8±0.1VDC or +2.7±0.1VDC by Tuner Type.	

Notes: TP301 --- Main CBA

Use Service remote control unit.

1. Enter the Service mode. (See Page 5-1) Then press number " 2 " button on the Service remote control unit.
2. Receive the Color Bar signal for channel 4 (67.25MHz). (RF Input Level: 60dBμV)
3. Press " CH ▲ / ▼ " buttons so that the voltage of TP301 becomes +2.5±0.1V DC. If the tuner is used TEDH9-300A. (Tuner type number)
4. Press " CH ▲ / ▼ " buttons so that the voltage of TP301 becomes +2.8±0.1V DC. If the tuner is used B8095AD. (Tuner type number)
5. Press " CH ▲ / ▼ " buttons so that the voltage of TP301 becomes +2.7±0.1V DC. If the tuner is used ENV56DB3G3. (Tuner type number)
6. Turn the Power off and on again. (Main power button on the TV unit.)

7. Black Level Adjustment

Purpose: Set Sub-bright Level

Symptom of Misadjustment: If Sub-brightness is incorrect, Proper brightness can not be obtained by adjusting the Bright ness Control.

Note: TP300 (GND), D316 (Cathode) --- MAIN CBA

1. Enter the Service mode. (See page 5-1).
2. Press " MENU " button on the Service remote control unit and select " BRT "mode. (Display changes " BRT ", " CNT ", " CLR " and " TNT "cyclically when MENU button is pressed).
3. Press " CH ▲ / ▼ " buttons on the Service remote control unit so that the value of " BRT " becomes 128.
4. Turn the power off and on again. (Main power button on the TV unit.)

8. C-Trap Adjustment

Purpose: To get minimum leakage of the color signal carrier.

Symptom of Misadjustment: If C- Trap Adjustment is incorrect, stripes will appears on the screen.

Test Point	Adj. Point	Mode	Input
D316 (Cathode) (Blue) TP300 (GND)	CH ▲ / ▼ buttons	RF	Color Bar
Tape	M. EQ.	Spec.	
---	Oscilloscope	---	

Note: TP300 (GND), D316 (Cathode) --- MAIN CBA
Use Service remote control unit.

1. Connect Oscilloscope to D316 (Cathode) and TP300 (GND).
2. Enter the Service mode. (See Page 5-1) Receive color bar signal from RF Input.
3. Press " 0 " button on the Service remote control unit and select C-TRP Mode.
4. Press " CH ▲ / ▼ " buttons on the Service remote control unit so that the display will change " 0 ", " 1 ", " 2 " and " 3 ". Choose display " 0 ", " 1 ", " 2 " or " 3 " when B-Out (3.58MHz) value becomes minimum on the oscilloscope reading.
5. Turn the power off and on again. (Main power button on the TV unit.)

9. V. Size Adjustment

Purpose: To obtain correct vertical width of screen image.

Symptom of Misadjustment: If V. Size is incorrect, vertical size of image on the screen may not be properly displayed.

Test Point	Adj. Point	Mode	Input
---	Screen Control CH ▲ / ▼ buttons [V-S] Mode	RF	Mono- scope
Tape	M. EQ.	Spec.	
---	Monoscope	90±5%	

Note: Use service remote control unit.

1. Operate the unit for at least 20 minutes.
2. Enter the Service mode. (See page 5-1)
3. Receive the Monoscope Pattern.
4. Press " 9 " button on the Service remote control unit and select " V-S " mode. (Display changes " V-S " and " V-P " cyclically when " 9 " button is pressed).
5. Press " CH ▲ / ▼ " buttons on the Service remote control unit so that the monoscope pattern will be 90±5% of display size and the circle is round.
6. Turn the power off and on again. (Main power button on the TV unit.)

10. V. Position Adjustment

Purpose: To obtain correct vertical width of screen image.

Symptom of misadjustment: If V. Position is incorrect, vertical height of image on the screen may not be properly displayed.

Test Point	Adj. Point	Mode	Input
---	Screen Control CH ▲ / ▼ buttons [V-P] Mode	RF	Mono- scope
Tape	M. EQ.	Spec.	
---	Monoscope	90±5%	

Note: Use Service remote control unit

1. Operate the unit for at least 20 minutes.
2. Enter the Service Mode. (See page 5-1)
3. Receive the Monoscope Pattern.
4. Press " 9 " button on the Service remote control unit and select " V-P " mode. (Display change " V-S " and " V-P " cyclically when " 9 " button is pressed).
5. Press " CH ▲ / ▼ " buttons on the Service remote control unit so that the top and bottom of the monoscope pattern will be equal of each other.
6. Turn the Power off and on again. (Main power button on the TV unit.)

11. H. Position Adjustment

Purpose: To obtain correct horizontal position of screen image.

Symptom of Misadjustment: If H. Position is incorrect, horizontal position of image on the screen may not be properly displayed.

Test Point	Adj. Point	Mode	Input
---	Screen Control CH ▲ / ▼ buttons [H-P] Mode	RF	Mono- scope
Tape	M. EQ.	Spec.	
---	Monoscope	90±5%	

Note: Use Service remote control unit

1. Operate the unit for at least 20 minutes.
2. Enter the Service mode. (See page 5-1)
3. Receive the Monoscope Pattern.
4. Press " 8 " button on the remote control unit and select " H-P " mode.
5. Press " CH ▲ / ▼ " buttons on the Service remote control unit so that the monoscope pattern will be 90±5% of display size and the circle is round.
6. Turn the Power off and on again. (Main power button on the TV unit.)

12. Cut-off Adjustment

Purpose: To adjust the beam current of R, G, B, and screen voltage.

Symptom of Misadjustment: White color may be reddish, greenish or bluish.

Test Point	Adj. Point	Mode	Input
---	Screen-Control CH ▲ / ▼ buttons	RF	Black Raster
Tape	M. EQ.	Spec.	
---	Pattern Generator	See Reference Notes below.	

Figure

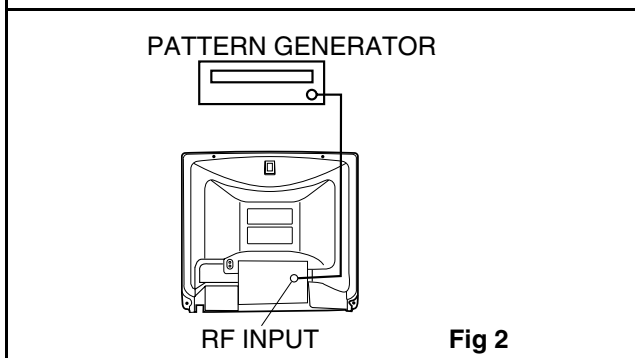

Fig 2

Note: Screen Control FBT --- Main CBA
F.B.T= Fly Back Transformer
Use Service remote control unit

1. Degauss the CRT and allow CRT to operate for 20 minutes before starting the alignment.
2. Input the Black Raster Signal from RF Input.
3. Enter the Service mode. (See page 5-1)
4. Press " VOL ▼ " button on the Service remote control unit and select " C/D " mode. (Display changes " C/D ", " VCO ", " 7F " and " FRENCH " cyclically when " VOL ▼ " button is pressed.) then press " 1 ". The display will momentarily show " CUT OFF R " (R= Red). Now there should be a horizontal line across the center of the picture tube. If needed gradually turn the screen control on the flyback, clockwise until the horizontal line appears. Adjust the Red Cut off by pressing the " CH ▲ / ▼ " buttons. Proceed to Step 5 when the Red Cut off adjustment is done.
5. Press the " 2 " button. The display will momentarily show " CUT OFF G " (G=Green). Adjust the Green Cut off by pressing the " CH ▲ / ▼ " buttons. Proceed to step 6 when the Green Cut off adjustment is done.
6. Press the " 3 " button. The display will momentarily show " CUT OFF B " (B=Blue). Adjust the Blue cut off by pressing the " CH ▲ / ▼ " buttons. When done with steps 4, 5 and 6 the horizontal line should be pure white if not, then attempt the Cut off adjustment again.

13. White Balance Adjustment

Purpose: To mix red, green and blue beams correctly for pure white.

Symptom of Misadjustment: White becomes bluish or reddish.

Test Point	Adj. Point	Mode	Input
Screen	Screen-Control CH ▲ / ▼ buttons	RF	White Raster (APL 100%)
Tape	M. EQ.	Spec.	
	Pattern Generator, Color analyzer	See below	

Figure

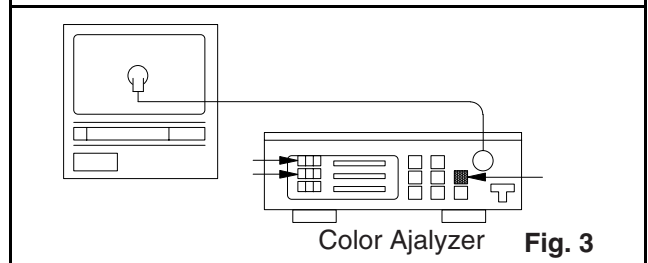

Fig. 3

Note: Use Service remote control unit

1. Operate the unit more than 20 minutes.
2. Face the unit to east. Degauss the CRT using De-gaussing Coil.
3. Input the White Raster (APL 100%).
4. Set the color analyzer to the CHROMA mode and after zero point calibration, bring the optical receptor to the center on the tube surface (CRT).
5. Enter the Service mode . Press " VOL ▼ " button on the Service remote control unit and select " C/D " mode. (Display changes " C/D ", " VCO ", " 7F " and " FRENCH " cyclically when " VOL ▼ " button is pressed.) then Press No. 8 button on the Service remote control Unit.
6. Press No. 4 button on the service remote control unit for Red adjustment. Press NO. 5 button on the Service remote control unit for Blue adjustment.
7. In each color mode, Press " CH ▲ / ▼ " button to adjust the values of color.
8. Adjusting Red and Blue color so that the temperature becomes 9200K (x : 286 / y : 294)±3%.
9. At this time, Re-check that Horizontal line is white. If not, Re-adjust Cut-off Adjustment until the Horizontal Line becomes pure white.
10. Turn off and on again to return to normal mode. Receive APL 100% white signal and Check Chroma temperatures become 9200K (x : 286 / y : 294)±3%.

Note: Confirm that Cut Off Adj. is correct after this adjustment, and attempt Cut Off Adj. if needed.

14. Sub-Brightness Adjustment

Purpose: To get proper brightness.

Symptom of Misadjustment: If Sub-Brightness is incorrect, proper brightness cannot be obtained by adjusting the Brightness Control.

Test Point	Adj. Point	Mode	Input
---	CH ▲ / ▼ buttons	RF	IQW
Tape	M. EQ.	Spec.	
---	Pattern Generator	See below	

Figure

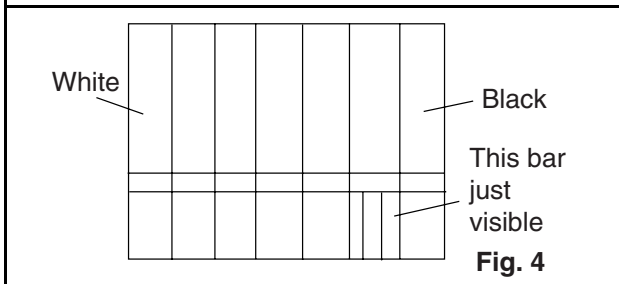

Note: IQW Setup level --- 7.5 IRE
Use Service remote control unit

1. Enter the Service mode. (See page 5-1)
Then input IQW signal from RF Input.
2. Press "MENU" button on the Service remote control unit and Select "BRT" mode. (Display changes "BRT", "CNT", "CLR", and "TNT" cyclically when MENU button is pressed). Press "CH ▲ / ▼" buttons so that the bar is just visible (See above figure).
3. Turn the power off and on again. (Main power button on the TV unit.)

15. Focus Adjustment

Purpose: Set the optimum Focus.

Symptom of Misadjustment: If Focus Adjustment is incorrect, blurred images are shown on the display.

Test Point	Adj. Point	Mode	Input
---	Focus Control	RF	Monoscope
Tape	M. EQ.	Spec.	
---	Pattern Generator	See below	

Note: Focus VR (FBT) - Main CBA FBT=Fly Back Transformer

1. Operate the unit more than 30 minutes
2. Face the unit to the East and Degauss the CRT using Degaussing Coil.
3. Input the Monoscope Pattern.
4. Adjust the Focus Control on the FBT to obtain clear picture.

The following 2 adjustments normally are not attempted in the field. Only when replacing the CRT then adjust as a preparation.

16. Purity Adjustment

Purpose: To obtain pure color.

Symptom of Misadjustment: If Color Purity Adjustment is incorrect, large areas of color may not be properly displayed.

Test Point	Adj. Point	Mode	Input
---	Deflection Yoke Purity Magnet	---	Red Color
Tape	M. EQ.	Spec.	
---	Pattern Generator	See below.	

Figure

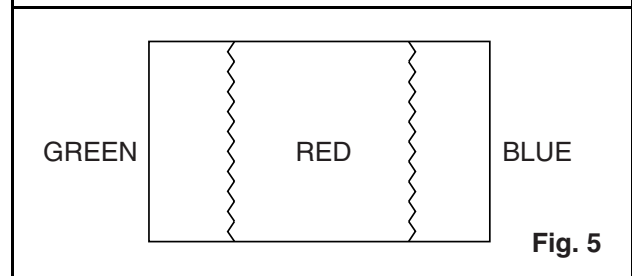

1. Set the unit facing east.
2. Operate the unit for over 30 minutes before adjusting.
3. Fully degauss the unit using an external degaussing coil.

4. Loosen the screw on the Deflection Yoke Clamper and pull the Deflection Yoke back away from the screen. (See Fig. 6)
5. Loosen the Ring Lock and adjust the Purity Magnets so that a red field is obtained at the center of the screen. Tighten Ring Lock. (See Fig. 5,6)
6. Slowly push the Deflection Yoke toward bell of CRT and set it where a uniform red field is obtained.
7. Tighten the clamp screw on the Deflection Yoke.

17. Convergence Adjustment

Purpose: To obtain proper convergence of red, green and blue beams.

Symptom of Misadjustment: If Convergence Adjustment is incorrect, the edge of white letters may have color edges.

Test Point	Adj. Point	Mode	Input
---	C.P. Magnet (RB), C.P. Magnet (RB-G), Deflection Yoke	---	Dot Pattern or Crosshatch
Tape	M. EQ.	Spec.	
---	Pattern Generator	See below.	
Figure			

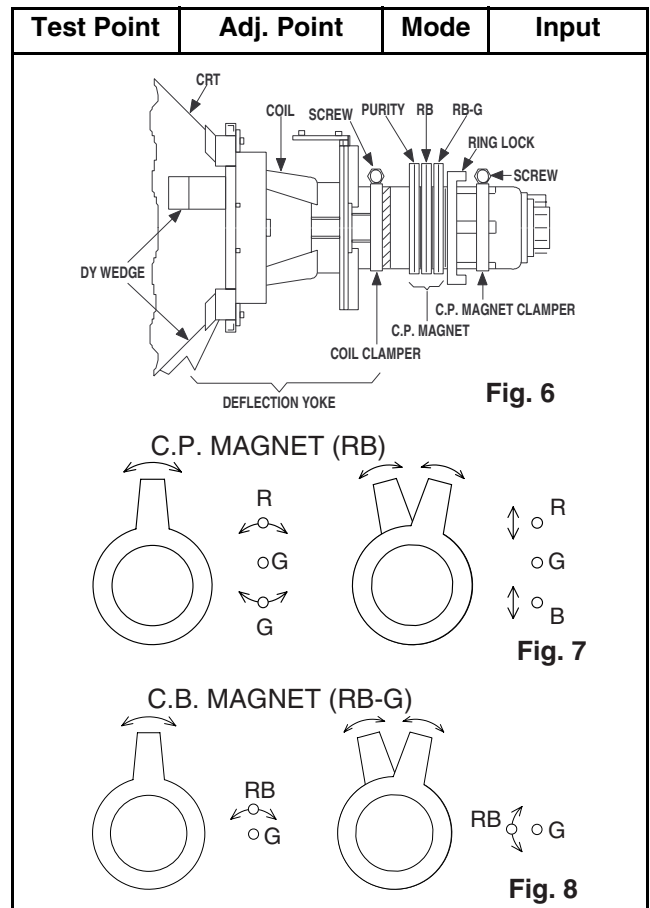

1. Loosen the Ring Lock and align red with blue dots or Crosshatch at the center of the screen by rotating (RB) C.P. Magnets. (See Fig. 7)
2. Align red / blue with green dots at the center of the screen by rotating (RB-G) C.P. Magnet. (See Fig. 8)
3. Fix the C.P. Magnets by tightening the Ring Lock.
4. Remove the DY Wedges and slightly tilt the Deflection Yoke horizontally and vertically to obtain the best overall convergence.
5. Fix the Deflection Yoke by carefully inserting the DY Wedges between CRT and Deflection Yoke.

BLOCK DIAGRAMS

IF/Video/System Control Block Diagram

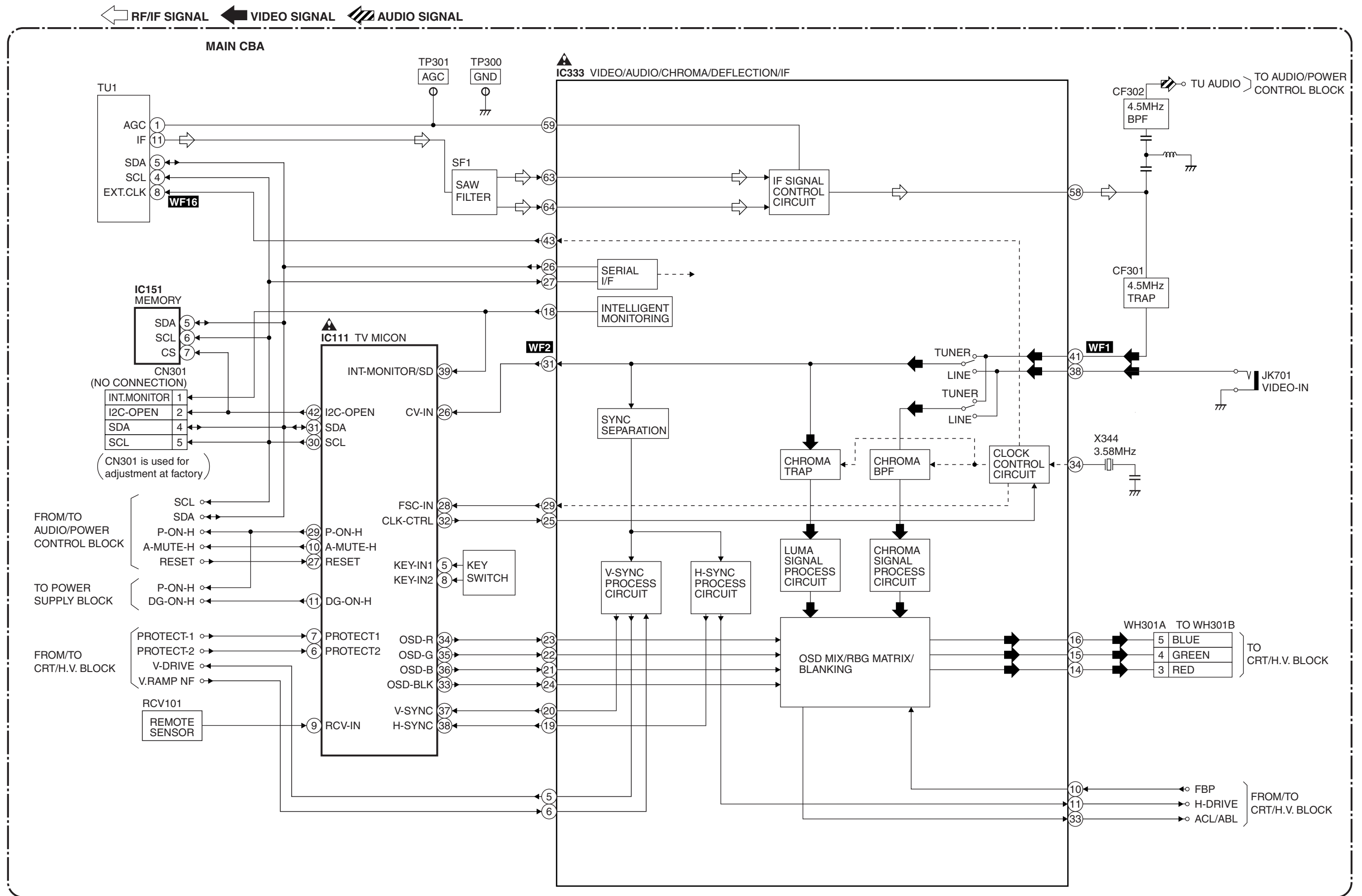

Audio/Power Control Block Diagram

 AUDIO SIGNAL

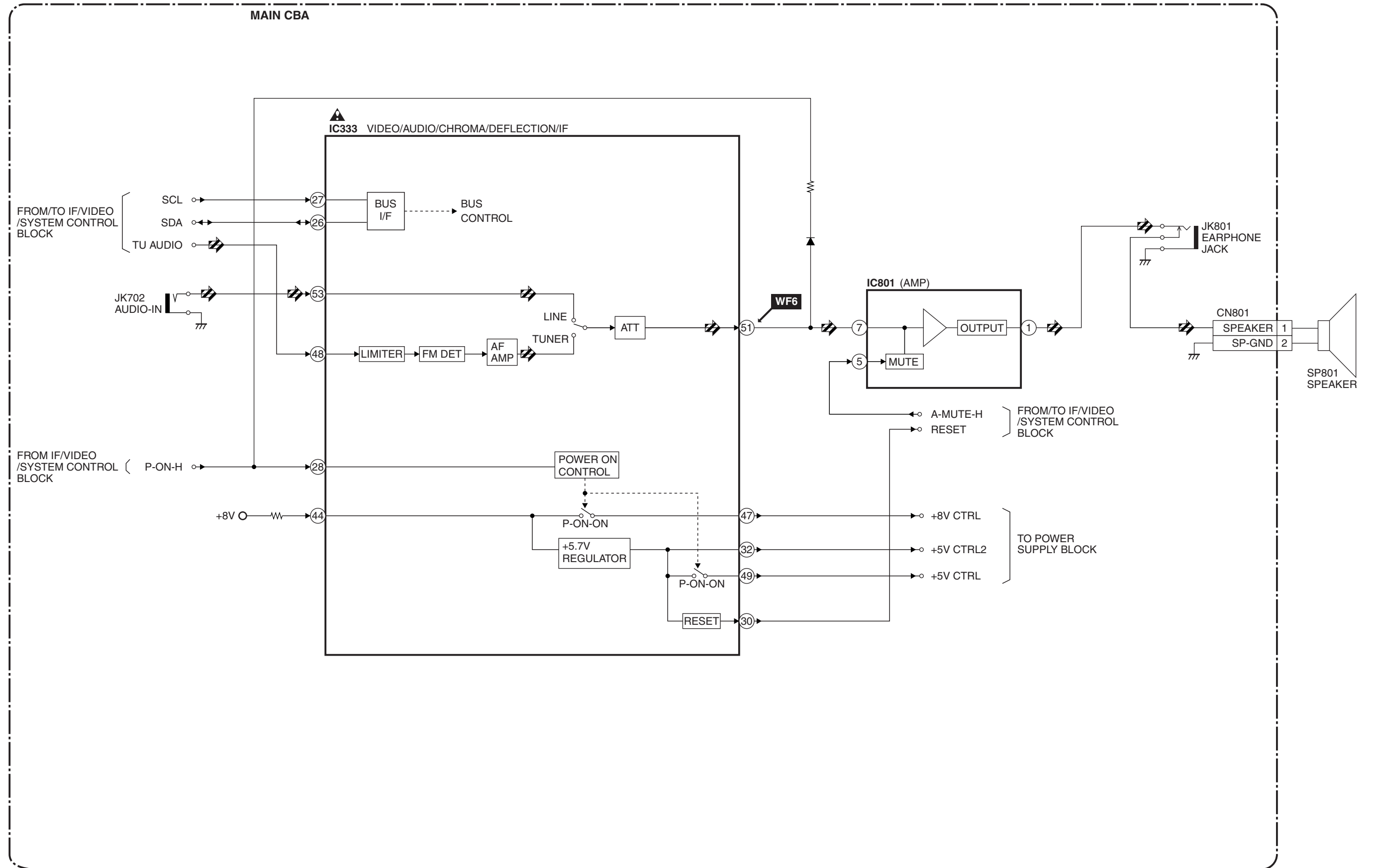

CRT/H.V. Block Diagram

← VIDEO SIGNAL

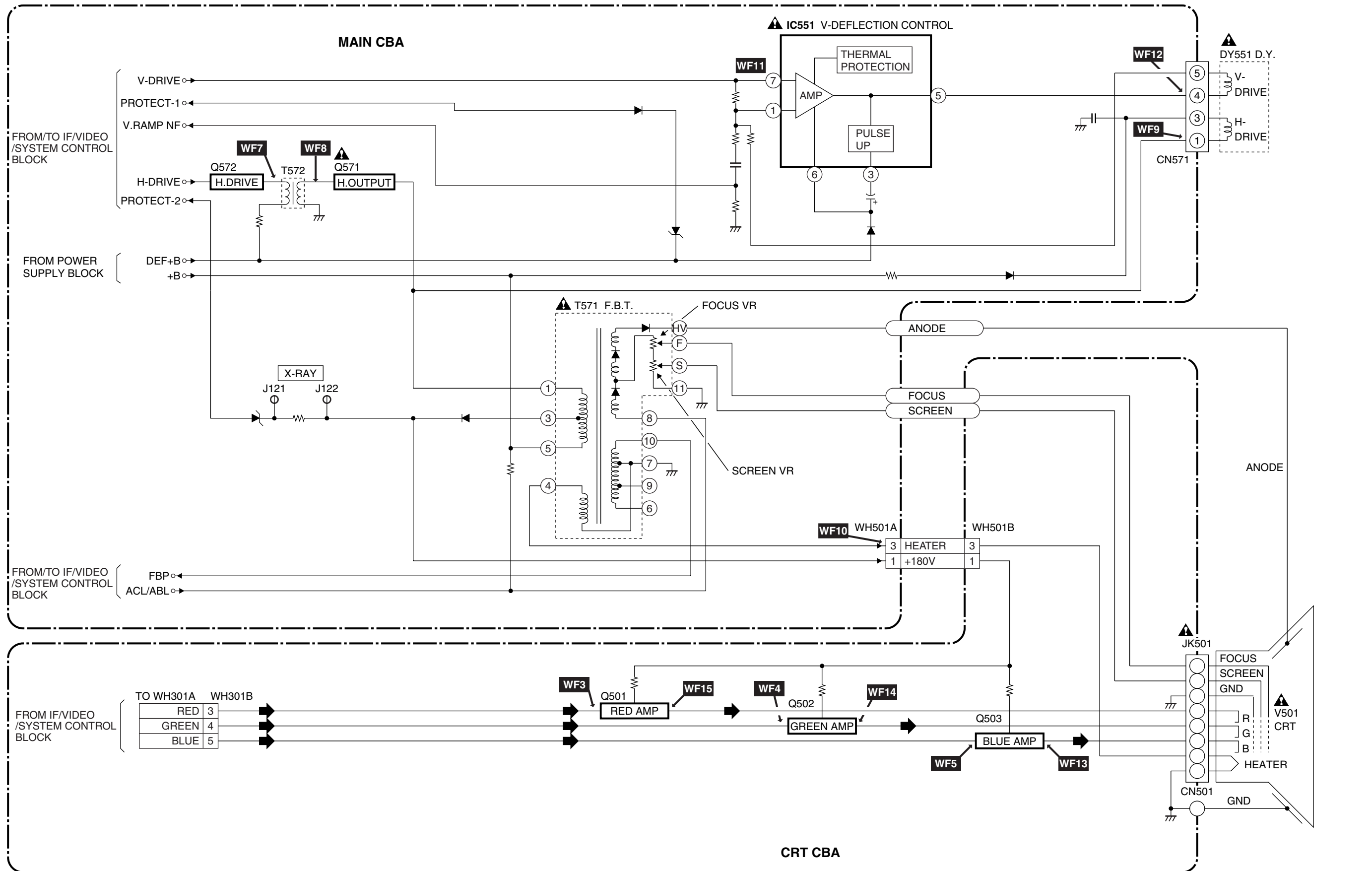

Power Supply Block Diagram

CAUTION !

Switching power supply circuit is used in this unit.
If Main Fuse (F601) is blown, check to see that all components in the power supply circuit are not defective before you connect the AC plug to the AC power supply.
Otherwise it may cause some components in the power supply circuit to fail.

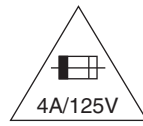

CAUTION

FOR CONTINUED PROTECTION AGAINST FIRE HAZARD,
REPLACE ONLY WITH THE SAME TYPE FUSE.
ATTENTION : POUR UNE PROTECTION CONTINUE LES RISQUES
D'INCELE N'UTILISER QUE DES FUSIBLE DE MEMO TYPE.
RISK OF FIRE-REPLACE FUSE AS MARKED.

"This symbol means fast operating fuse."
"Ce symbole représente un fusible à fusion rapide."

NOTE :

The voltage for parts in hot circuit is measured using hot GND as a common terminal.

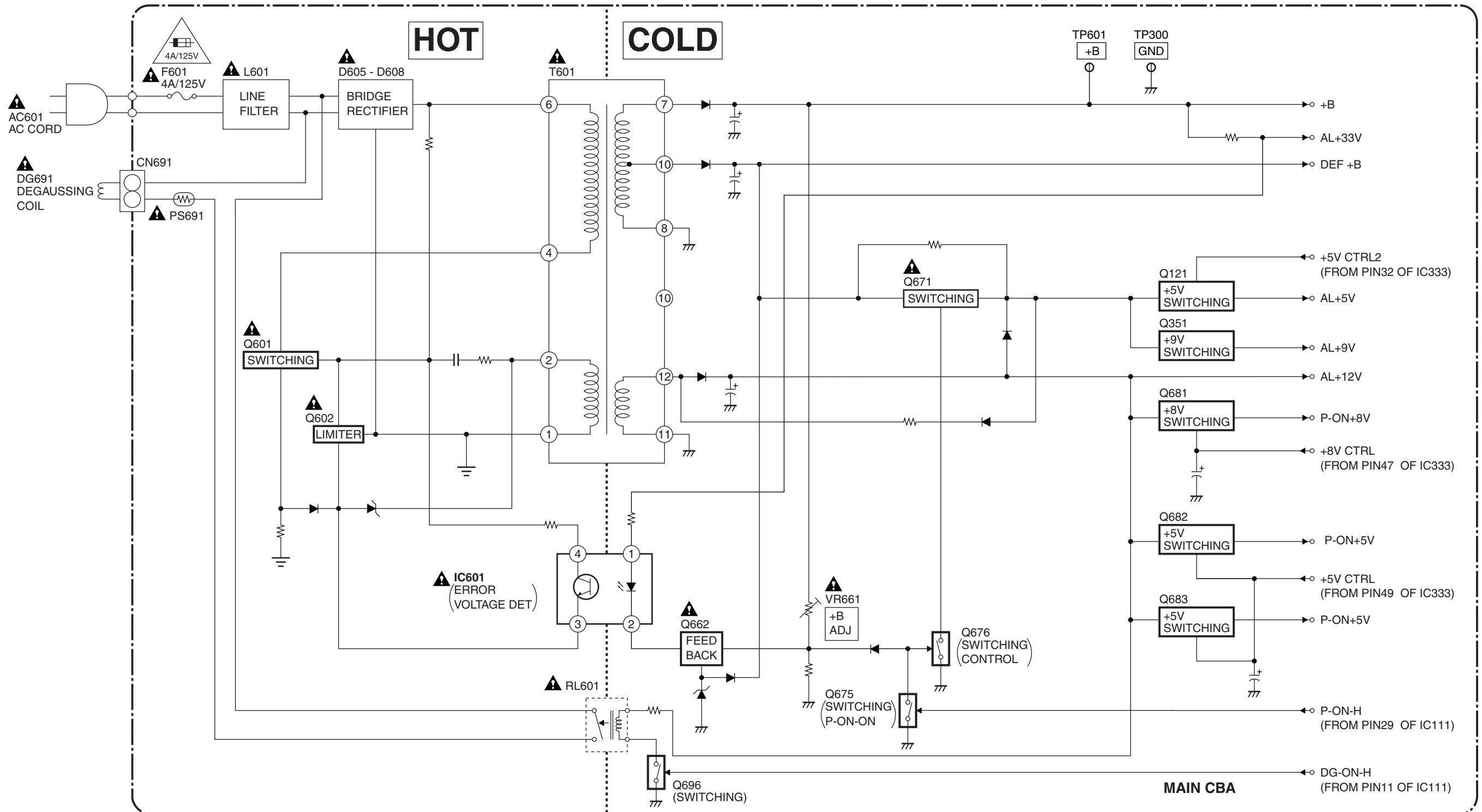

SCHEMATIC DIAGRAMS / CBA'S AND TEST POINTS

Standard Notes

Many electrical and mechanical parts in this chassis have special characteristics. These characteristics often pass unnoticed and the protection afforded by them cannot necessarily be obtained by using replacement components rated for higher voltage, wattage, etc. Replacement parts that have these special safety characteristics are identified in this manual and its supplements; electrical components having such features are identified by the mark "▲" in the schematic diagram and the parts list. Before replacing any of these components, read the parts list in this manual carefully. The use of substitute replacement parts that do not have the same safety characteristics as specified in the parts list may create shock, fire, or other hazards.

Note:

1. Do not use the part number shown on these drawings for ordering. The correct part number is shown in the parts list, and may be slightly different or amended since these drawings were prepared.
2. All resistance values are indicated in ohms ($K=10^3$, $M=10^6$).
3. Resistor wattages are 1/4W or 1/6W unless otherwise specified.
4. All capacitance values are indicated in μF ($P=10^{-6}\mu F$).
5. All voltages are DC voltages unless otherwise specified.

Note of Capacitors:

ML --- Mylar Cap. PP --- Metalized Film Cap. SC --- Semiconductor Cap. L --- Low Leakage type

Temperature Characteristics of Capacitors are noted with the following:

B --- $\pm 10\%$ CH --- $0\pm 60\text{ppm}/^\circ\text{C}$ CSL --- $+350\sim 1000\text{ppm}/^\circ\text{C}$

Tolerance of Capacitors are noted with the following:

Z --- $+80\sim -20\%$

Note of Resistors:

CEM --- Cement Res. MTL --- Metal Res. F --- Fuse Res.

Capacitors and transistors are represented by the following symbols.

CBA Symbols

(Top View) (Bottom View)

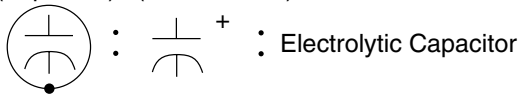

(Bottom View)

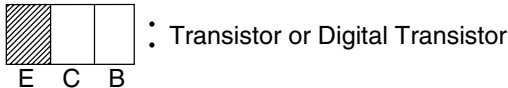

(Top View)

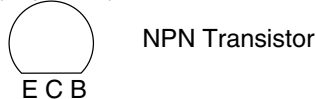

(Top View)

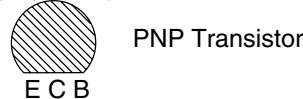

(Top View)

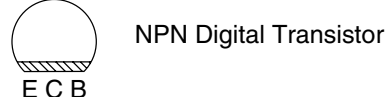

(Top View)

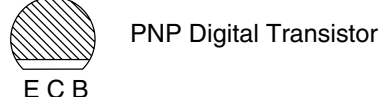

Schematic Diagram Symbols

Digital Transistor

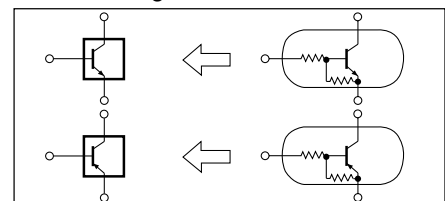

LILIST OF CAUTION, NOTES, AND SYMBOLS USED IN THE

SCHEMATIC DIAGRAMS ON THE FOLLOWING PAGES:

- CAUTION:** FOR CONTINUED PROTECTION AGAINST FIRE HAZARD, REPLACE ONLY WITH THE SAME TYPE FUSE. ATTENTION: POUR UNE PROTECTION CONTINUE LES RISQUES D'INCELE N'UTILISER QUE DES FUSIBLE DE MEMO TYPE.

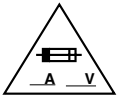

RISK OF FIRE-REPLACE FUSE AS MARKED.

2. CAUTION:

Fixed Voltage (or Auto voltage selectable) power supply circuit is used in this unit.

If Main Fuse (F601) is blown, first check to see that all components in the power supply circuit are not defective before you connect the AC plug to the AC power supply. Otherwise it may cause some components in the power supply circuit to fail.

3. Note:

- Do not use the part number shown on the drawings for ordering. The correct part number is shown in the parts list, and may be slightly different or amended since the drawings were prepared.
- To maintain original function and reliability of repaired units, use only original replacement parts which are listed with their part numbers in the parts list section of the service manual.

4. Wire Connectors

- Prefix symbol "CN" means "connector" (can disconnect and reconnect).
- Prefix symbol "CL" means "wire-solder holes of the PCB" (wire is soldered directly).

5. Note: Mark "●" is a leadless (chip) component.

6. Voltage indications on the schematics are as shown below:

Plug the TV power cord into a standard AC outlet.:

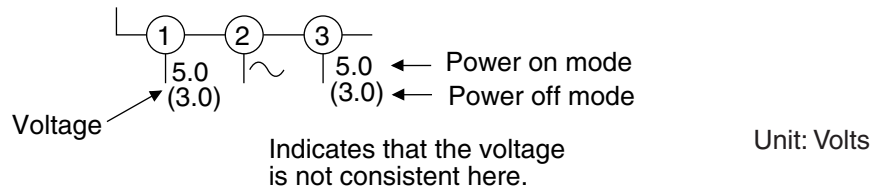

7. How to read converged lines

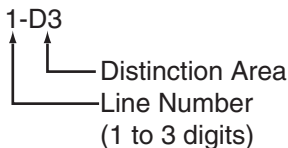

Examples:

- "1-D3" means that line number "1" goes to area "D3".
- "1-B1" means that line number "1" goes to area "B1".

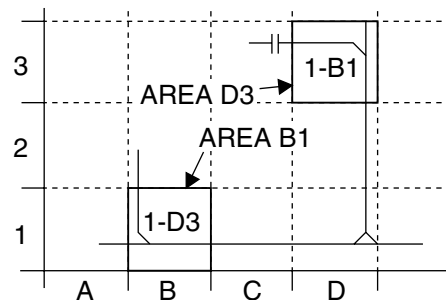

8. Test Point Information

- ⊕ : Indicates a test point with a jumper wire across a hole in the PCB.
- : Used to indicate a test point with a component lead on foil side.
- ⊘ : Used to indicate a test point with no test pin.
- : Used to indicate a test point with a test pin.

Main 1/2 Schematic Diagram

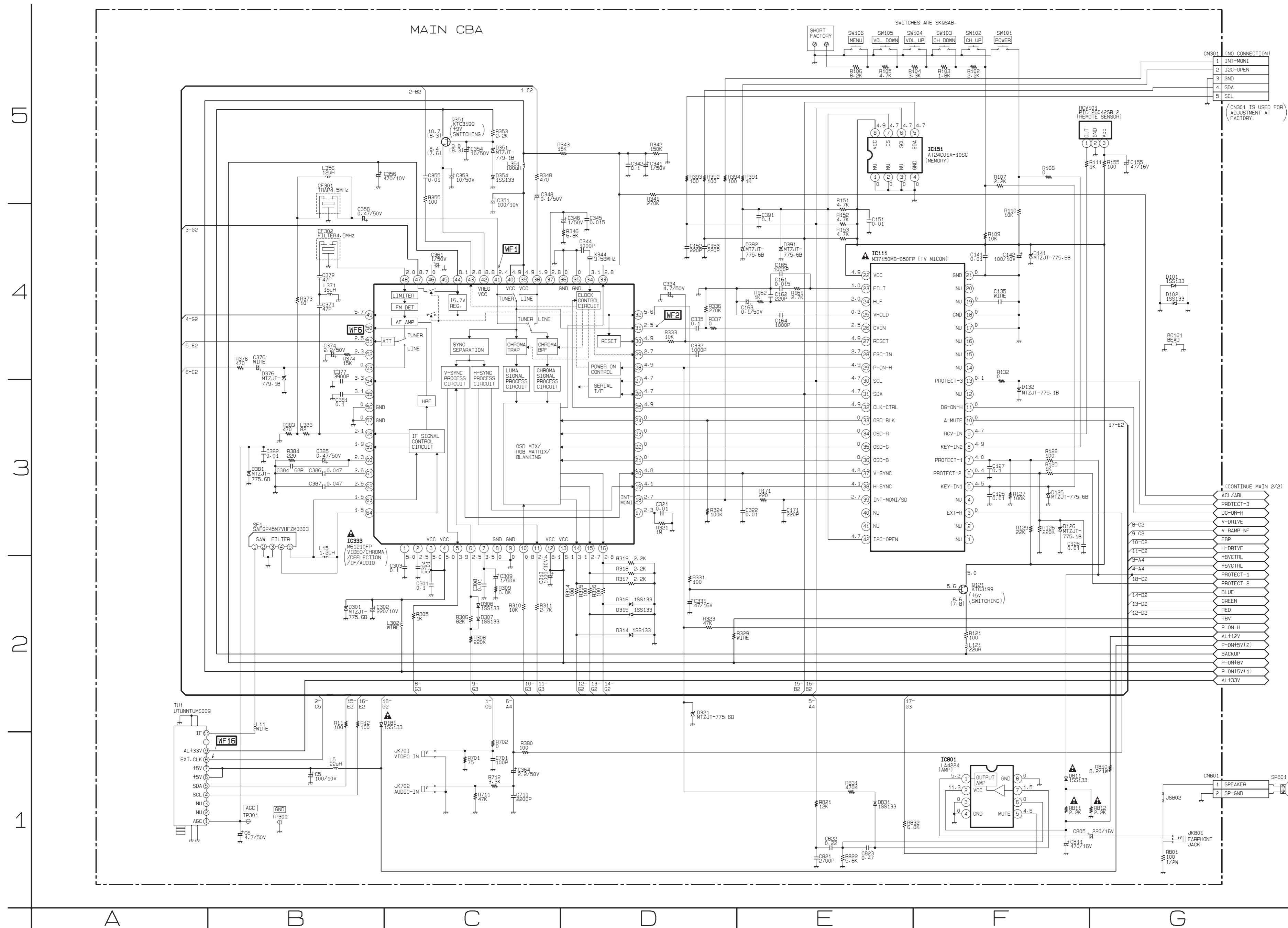

MAIN 1/2

Ref No.	Position
ICS	
IC111	E-4
IC151	F-5
IC333	B-3
IC801	F-1
TRANSISTORS	
Q121	F-2
Q351	C-5
TEST POINTS	
TP300	B-1
TP301	B-1
CONNECTORS	
CN301	G-5
CN801	G-1

01
 4
 3
 1

A B C D E F G

A5	B5	C5	D5	E5	F5	G5
A4	B4	C4	D4	E4	F4	G4
A3	B3	C3	D3	E3	F3	G3
A2	B2	C2	D2	E2	F2	G2
A1	B1	C1	D1	E1	F1	G1

--- IF SIGNAL
— VIDEO SIGNAL
◀ AUDIO SIGNAL

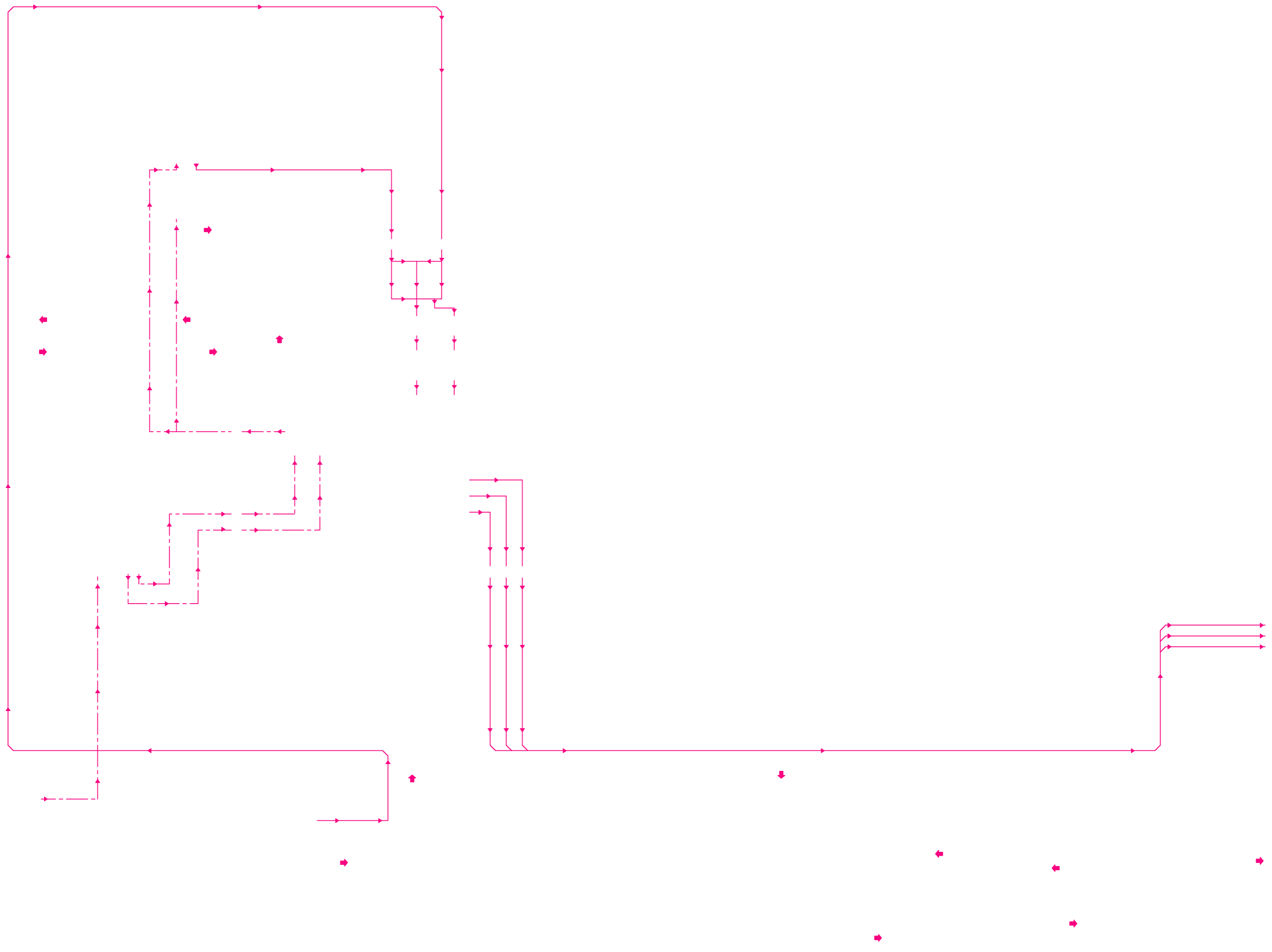

Main 2/2 & CRT Schematic Diagram

CAUTION !

Fixed voltage power supply circuit is used in this unit.
If Main Fuse (F601) is blown, check to see that all components in the power supply circuit are not defective before you connect the AC plug to the AC power supply.
Otherwise it may cause some components in the power supply circuit to fail.

NOTE :

The voltage for parts in hot circuit is measured using hot GND as a common terminal.

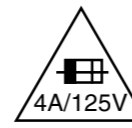

CAUTION

FOR CONTINUED PROTECTION AGAINST FIRE HAZARD,
REPLACE ONLY WITH THE SAME TYPE FUSE.
ATTENTION : POUR UNE PROTECTION CONTINUE LES RISQUES
D'INCELE N'UTILISER QUE DES FUSIBLE DE MEMO TYPE.
RISK OF FIRE-REPLACE FUSE AS MARKED.

This symbol means fast operating fuse.
Ce symbole représente un fusible à fusion rapide.

BECAUSE A HOT CHASSIS GROUND IS PRESENT IN THE POWER SUPPLY CIRCUIT, AN ISOLATION TRANSFORMER MUST BE USED. ALSO, IN ORDER TO HAVE THE ABILITY TO INCREASE THE INPUT SLOWLY, WHEN TROUBLESHOOTING THIS TYPE POWER SUPPLY CIRCUIT, A VARIABLE ISOLATION TRANSFORMER IS REQUIRED.

*1 NOTE:

The Capacitor (C643) is either type A or type B.
These two types are exchangeable and can be equally used whichever the model is . The difference between type A and type B is shown in the table below.

	C643	C642	JS642
Type A	0.01/250V	0.01/250V	Not Used
Type B	4700P/250V	Not Used	WIRE

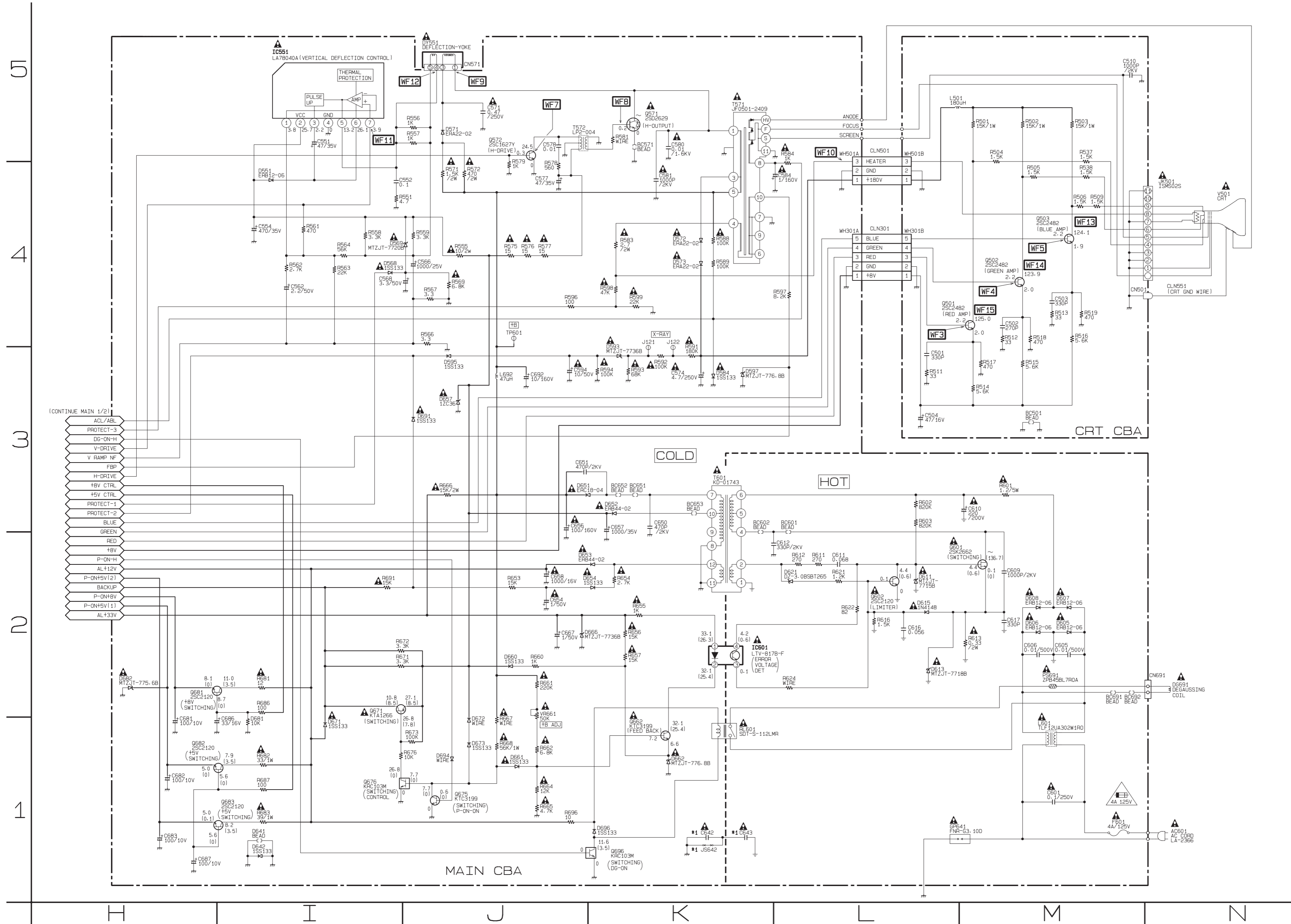

CRT

Ref No.	Position
TRANSISTORS	
Q501	L-4
Q502	M-4
Q503	M-4
CONNECTORS	
CN501	M-4
WH301B	L-4
WH501B	L-5

MAIN 2/2

Ref No.	Position
ICS	
IC551	I-5
IC601	K-2
TRANSISTORS	
Q571	K-5
Q572	J-5
Q601	L-2
Q602	L-2
Q662	K-1
Q671	I-2
Q675	J-1
Q676	I-1
Q681	H-2
Q682	H-1
Q683	I-1
Q696	K-1
TEST POINTS	
J121	K-4
J122	K-4
TP601	J-4
CONNECTORS	
CN571	J-5
CN691	N-2
WH301A	L-4
WH501A	L-5
VARIABLE RESISTORS	
VR661	J-2

H5	I5	J5	K5	L5	M5	N5
H4	I4	J4	K4	L4	M4	N4
H3	I3	J3	K3	L3	M3	N3
H2	I2	J2	K2	L2	M2	N2
H1	I1	J1	K1	L1	M1	N1

VIDEO SIGNAL

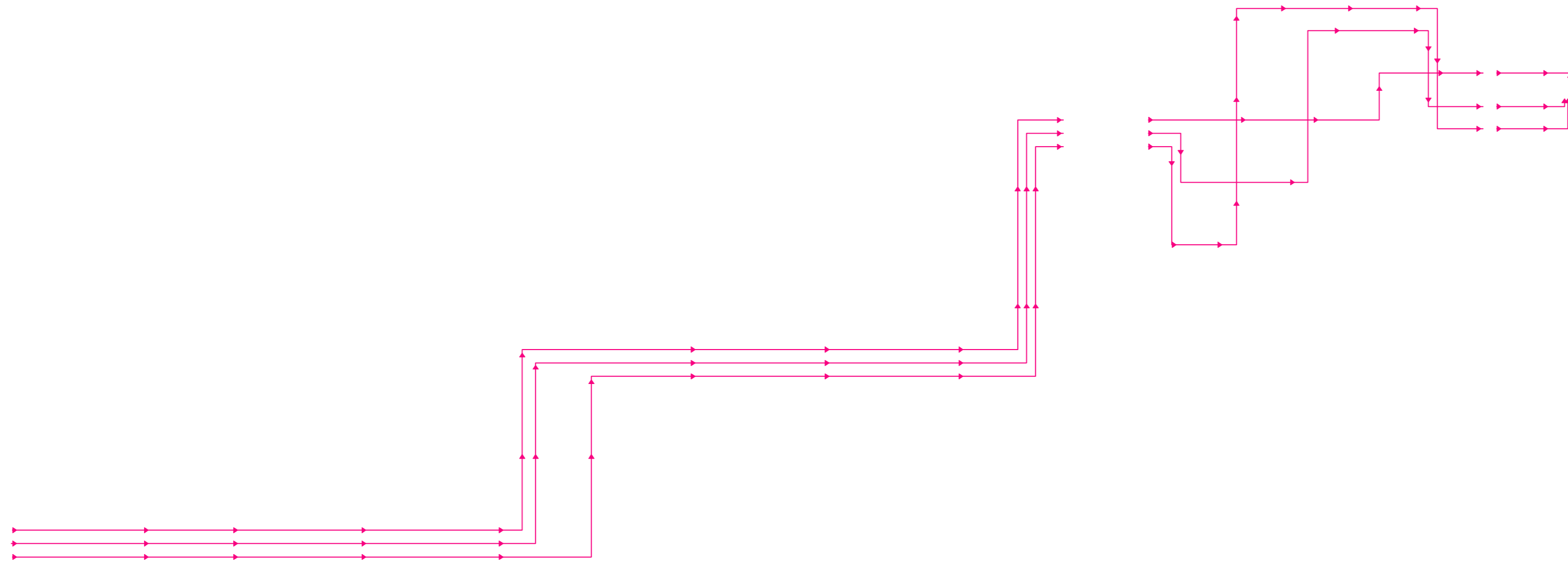

Main CBA Top View

CAUTION !
Fixed voltage power supply circuit is used in this unit.
If Main Fuse (F601) is blown, check to see that all components in the power supply circuit are not defective before you connect the AC plug to the AC power supply.
Otherwise it may cause some components in the power supply circuit to fail.



CAUTION
FOR CONTINUED PROTECTION AGAINST FIRE HAZARD,
REPLACE ONLY WITH THE SAME TYPE FUSE.
ATTENTION : POUR UNE PROTECTION CONTINUE LES RISQUES
D'INCELE N'UTILISER QUE DES FUSIBLE DE MEMO TYPE.
RISK OF FIRE-REPLACE FUSE AS MARKED.

This symbol means fast operating fuse.
Ce symbole représente un fusible à fusion rapide.

BECAUSE A HOT CHASSIS GROUND IS PRESENT IN THE POWER SUPPLY CIRCUIT, AN ISOLATION TRANSFORMER MUST BE USED. ALSO, IN ORDER TO HAVE THE ABILITY TO INCREASE THE INPUT SLOWLY, WHEN TROUBLESHOOTING THIS TYPE POWER SUPPLY CIRCUIT, A VARIABLE ISOLATION TRANSFORMER IS REQUIRED.

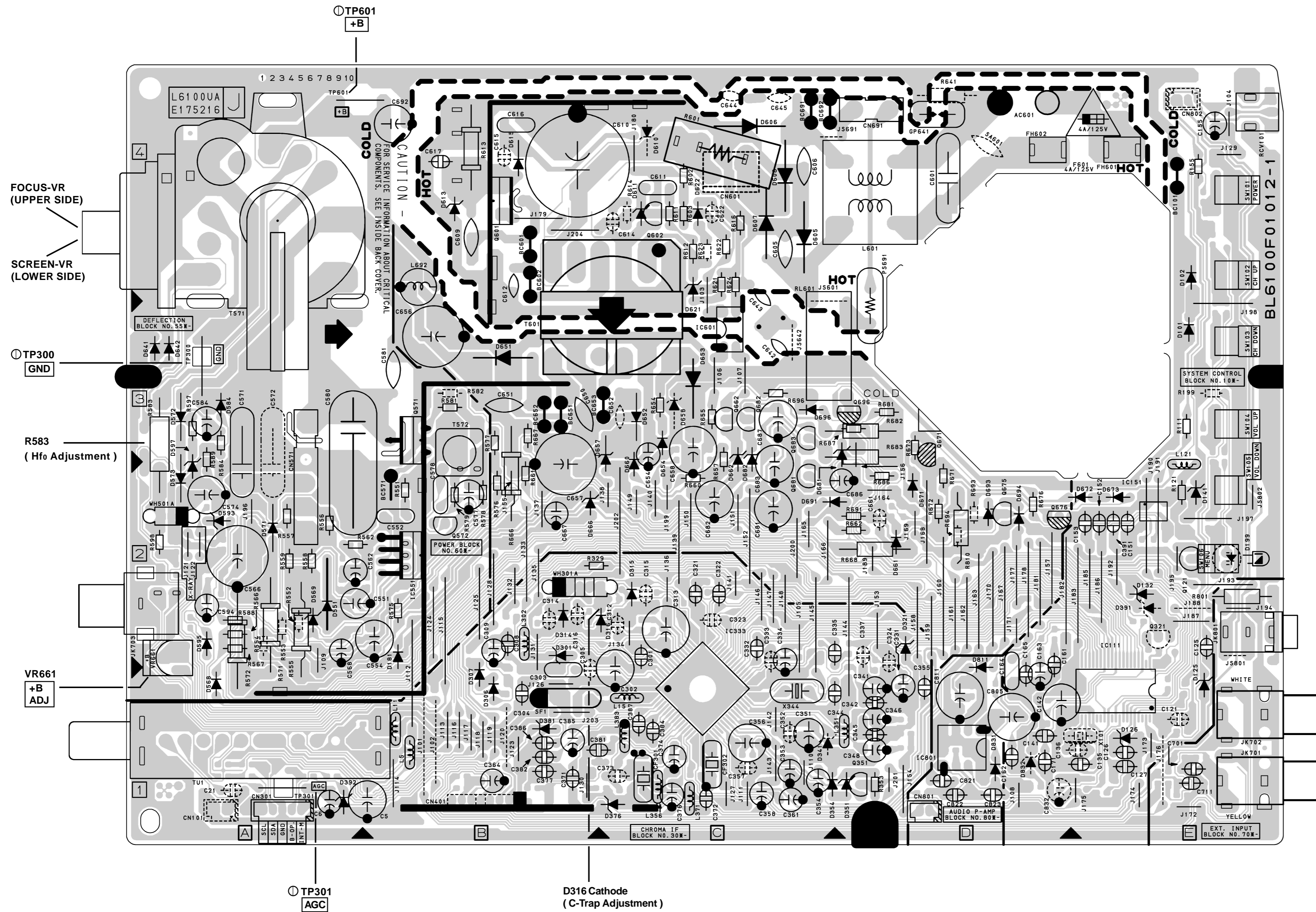

MAIN CBA

Ref No.	Position
ICS	
IC111	E-2
IC151	E-2
IC333	C-2
IC551	B-2
IC601	C-3
IC801	D-1
TRANSISTORS	
Q121	E-2
Q351	D-1
Q571	B-3
Q572	B-2
Q601	B-4
Q602	C-4
Q662	C-3
Q671	D-3
Q675	D-2
Q676	D-2
Q681	C-2
Q682	C-3
Q683	C-3
Q696	D-3
TEST POINTS	
J121	A-2
J122	A-2
TP300	A-3
TP301	A-1
TP601	A-4
CONNECTORS	
CN301	A-1
CN571	A-2
CN691	D-4
CN801	D-1
WH301A	B-2
WH501A	A-2
VARIABLE RESISTORS	
VR661	A-2

Main CBA Bottom View

CAUTION!
Fixed voltage power supply circuit is used in this unit.
If Main Fuse (F601) is blown, check to see that all components in the power supply circuit are not defective before you connect the AC plug to the AC power supply.
Otherwise it may cause some components in the power supply circuit to fail.

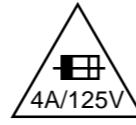

CAUTION
FOR CONTINUED PROTECTION AGAINST FIRE HAZARD,
REPLACE ONLY WITH THE SAME TYPE FUSE.
ATTENTION : POUR UNE PROTECTION CONTINUE LES RISQUES
D'INCELE N'UTILISER QUE DES FUSIBLES DE MEMO TYPE.
RISK OF FIRE-REPLACE FUSE AS MARKED.
"This symbol means fast operating fuse."
"Ce symbole représente un fusible à fusion rapide."

BECAUSE A HOT CHASSIS GROUND IS PRESENT IN THE POWER SUPPLY CIRCUIT, AN ISOLATION TRANSFORMER MUST BE USED. ALSO, IN ORDER TO HAVE THE ABILITY TO INCREASE THE INPUT SLOWLY, WHEN TROUBLESHOOTING THIS TYPE POWER SUPPLY CIRCUIT, A VARIABLE ISOLATION TRANSFORMER IS REQUIRED.

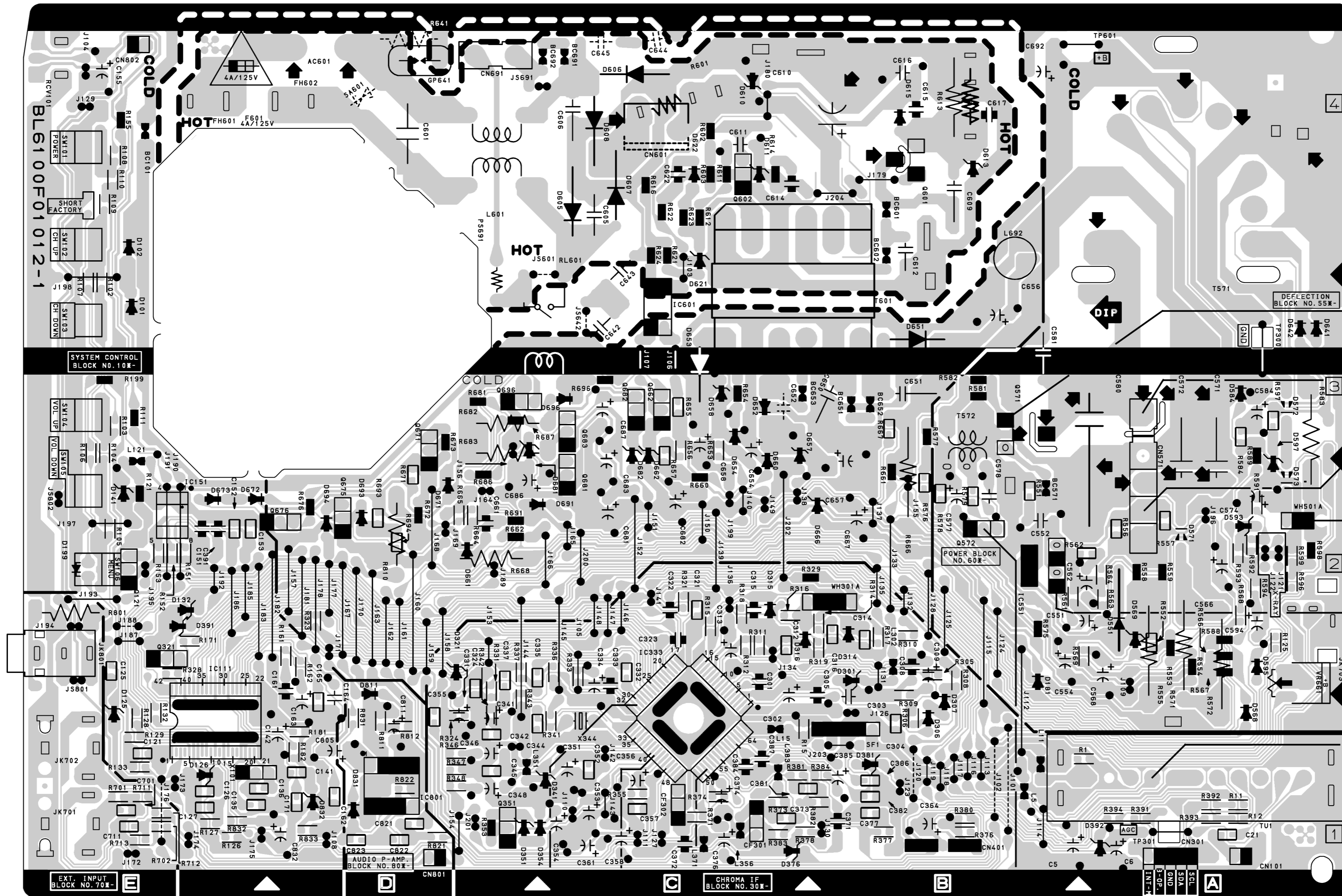

WF8
Q571
Base

WF9
PIN 1
OF CN571

WF12
PIN 4
OF CN571

WF10
PIN 3
OF WH501A

WF11
PIN 7
OF IC551

WF16
PIN 8
OF TU1

WF2
PIN 31
OF IC333

WF1
PIN 41
OF IC333

WF6
PIN 51
OF IC333

WF7
Q572
Collector

CRT CBA Top View

CRT CBA Bottom View

CRT CBA

Ref No.	Position
TRANSISTORS	
Q501	B-2
Q502	B-2
Q503	B-2
CONNECTORS	
CN501	A-2
WH301B	B-1
WH501B	B-1

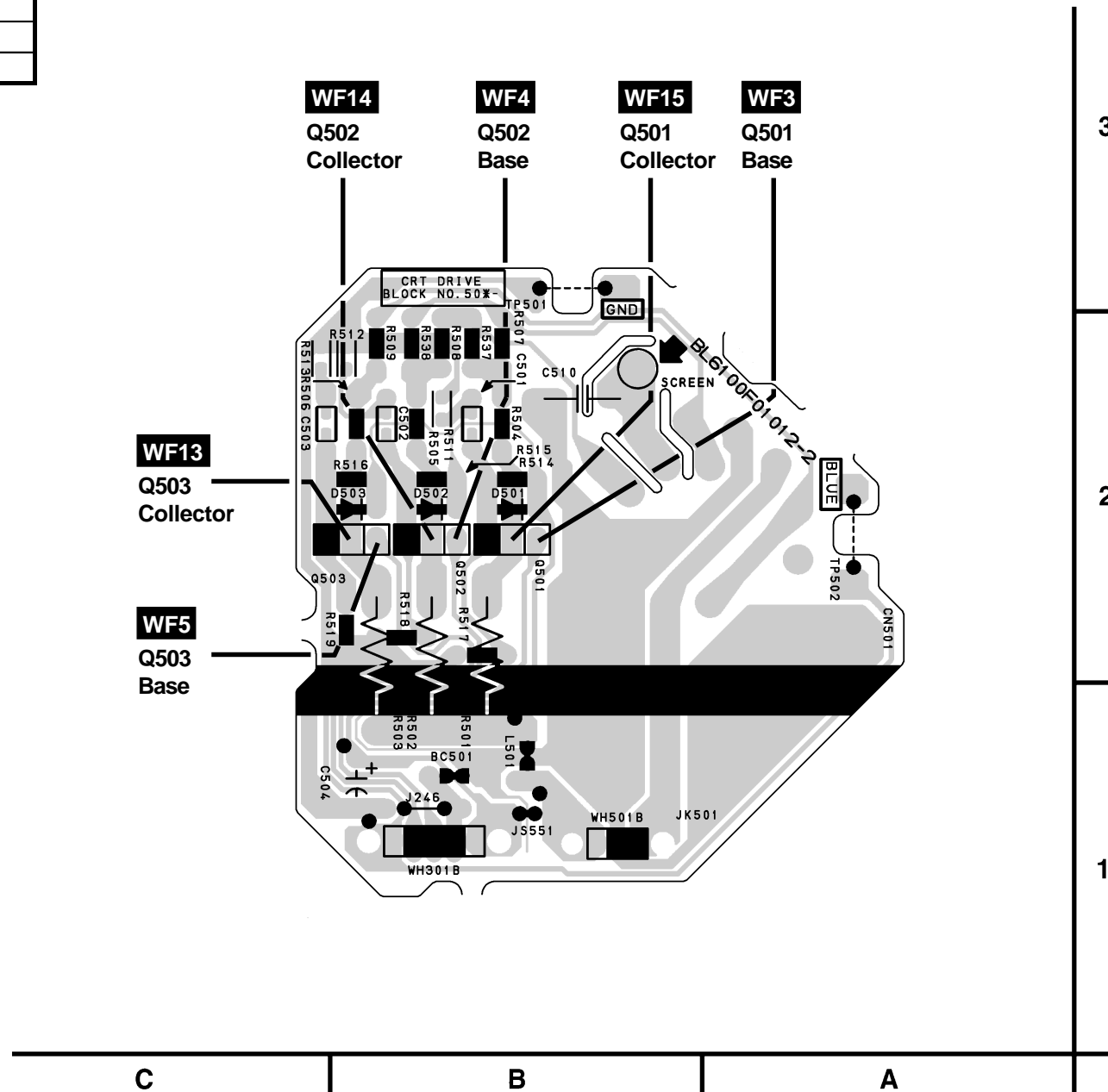
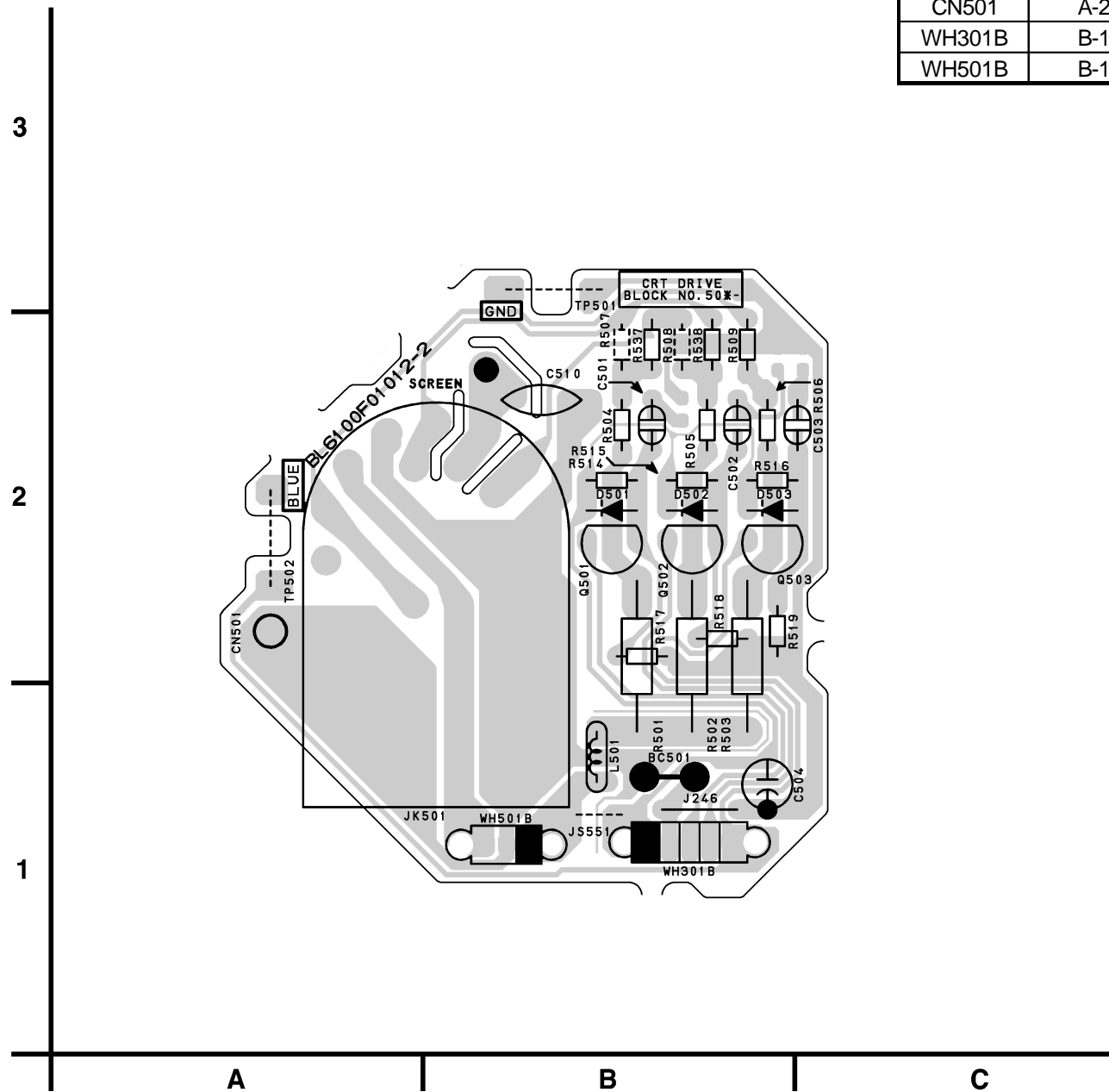

WAVEFORMS

WF1 ~ WF16 = Waveforms to be observed at Waveform check points. (Shown in Schematic Diagram.)

Input: NTSC Color Bar Signal (with 1kHz Audio Signal)
INITIAL POSITION: Unplug unit from AC outlet for at least 5 minutes. reconnect to AC outlet and then turn power on.
(Brightness---Center Color---Center Tint --- Center Contrast---Approx 70%)

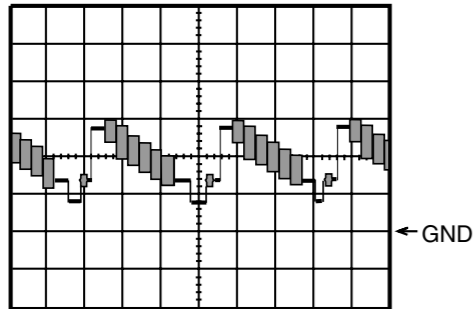

WF1 1DIV: 0.5V 20 sec
IC 333 Pin 41

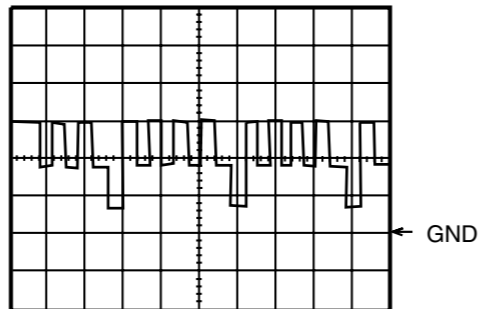

WF5 1DIV: 2V 20 sec
Q 503 Base

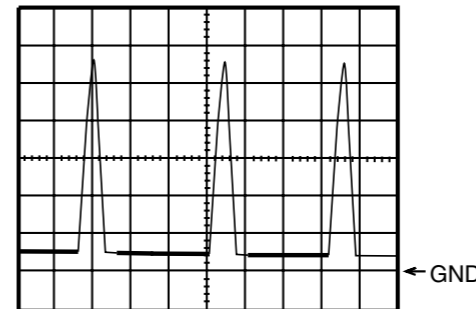

WF9 1DIV: 200V 20 sec
CN 571 Pin 1

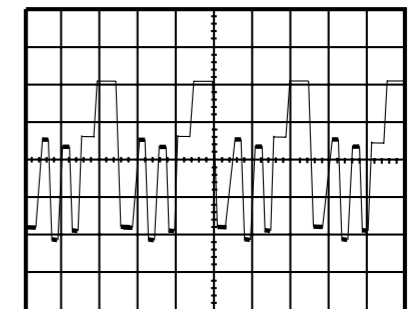

WF13 1DIV: 20V 20 sec
Q503 Collector

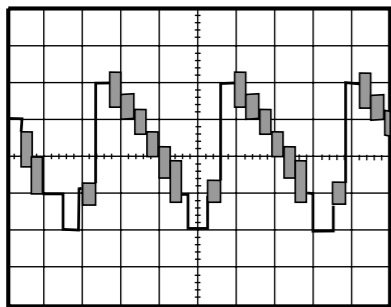

WF2 1DIV: 0.5V 20 sec
IC 333 Pin 31

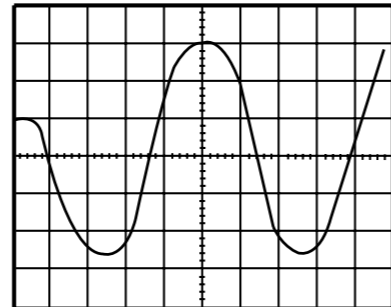

WF6 1DIV: 0.2V 20msec
IC 333 Pin 51

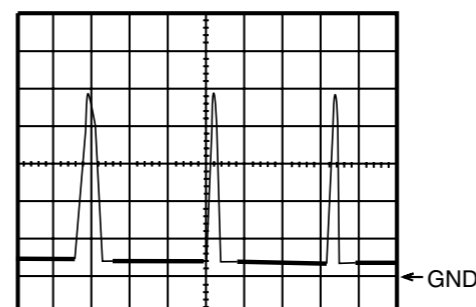

WF10 1DIV: 5V 20 sec
WH501A Pin 3

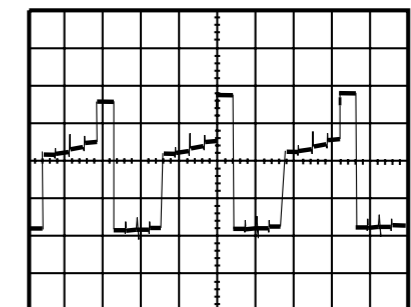

WF14 1DIV: 20V 20 sec
Q 502 Collector

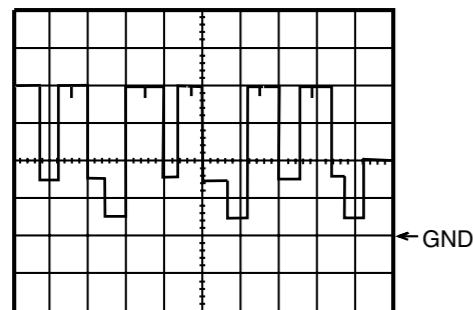

WF3 1DIV: 2V 20 sec
Q501 Base

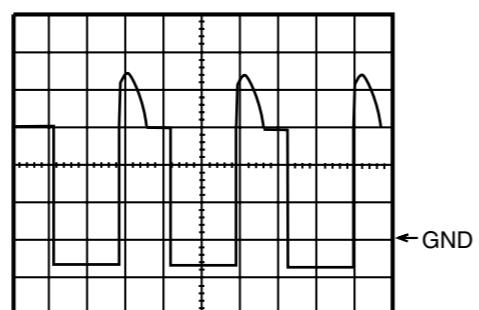

WF7 1DIV: 10V 20 sec
Q 572 Collector

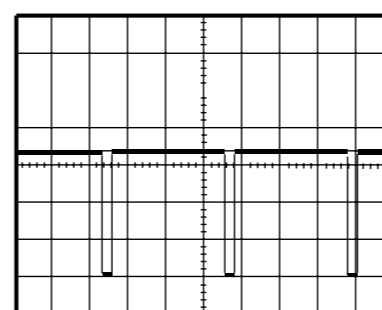

WF11 1DIV: 2V 5msec
IC 551 Pin 7

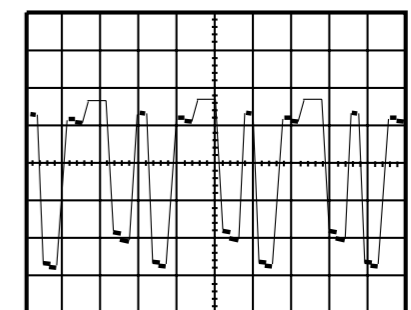

WF15 1DIV: 20V 20 sec
Q 501 Collector

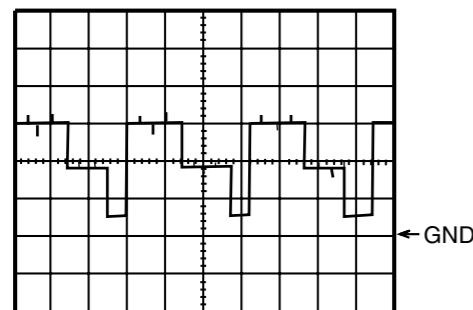

WF4 1DIV: 2V 20 sec
Q 502 Base

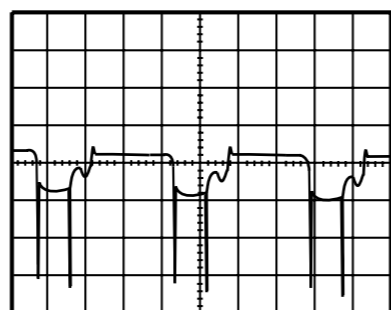

WF8 1DIV: 5V 20 sec
Q 571 Base

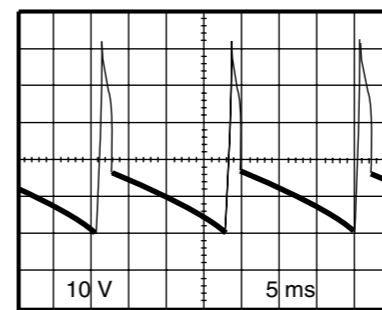

WF12 1DIV: 10V 5msec
CN 571 Pin 4

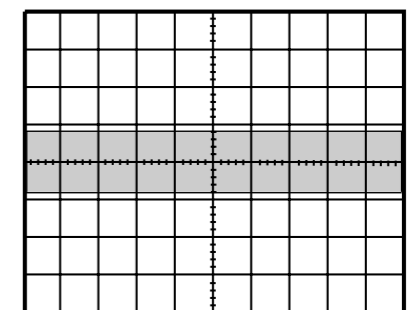

WF16 1DIV: 0.2V 20 sec
TU 1 Pin 8

WIRING DIAGRAM

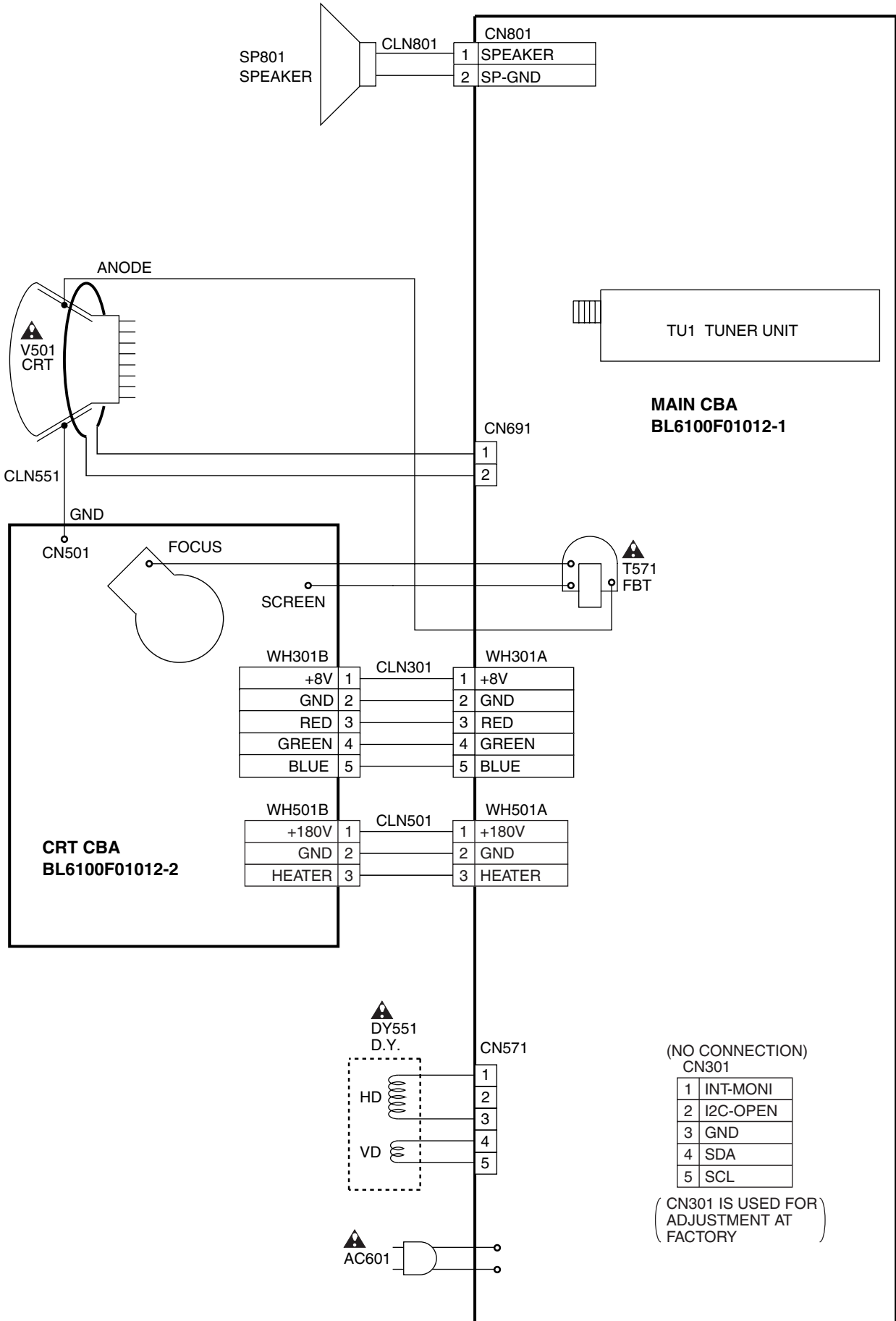

IC PIN FUNCTIONS

IC111(TV Micro Computer)

Pin No.	Signal Name	Function
1	N.U.	Not Used
2	N.U.	Not Used
3	EXT-H	Ext-H
4	N.U.	Not Used
5	KEY-IN 1	Key Input 1 (Main)
6	PROTECT-2	Power Supply Protection
7	PROTECT-1	Power Supply Protection
8	KEY-IN 2	Key Input 2 (Main)
9	RCV-IN	Input For Remote Control
10	A-MUTE-H	Audio Mute
11	DG-ON-H	Degaussing Coil Control
12	N.U.	Not Used
13	PROTECT-3	Power Supply Protection
14	N.U.	Not Used
15	N.U.	Not Used
16	N.U.	Not Used
17	N.U.	Not Used
18	GND	GND
19	N.U.	Not Used
20	N.U.	Not Used
21	VSS	GND
22	VCC	+5V
23	FILT	PLL Filter
24	HLF	Filter for CCD
25	VHOLD	VHOLD
26	CVIN	Input for Video Signal
27	RESET	RESET
28	FSC-IN	External Clock Input
29	P-ON-H	Output for P-ON-H
30	SCL	I2C-BUS ControllerInterface (Clock)
31	SDA	I2C-BUS ControllerInterface (Data)
32	CLK-CTRL	Clock Control Signal
33	OSD-BLK	Picture Shut Down Output
34	OSD-R	Red Output

Pin No.	Signal Name	Function
35	OSD-G	Green Output
36	OSD-B	Blue Output
37	V-SYNC	Input For Vertical Synchronize Signal
38	H-SYNC	Input For Horizontal Synchronize Signal
39	INT-MONI/ SD	Intelligent Monitor/ Detection SD signal
40	N.U.	Not Used
41	N.U.	Not Used
42	I2C-OPEN	White Balance Adjustment Judgement

EXPLODED VIEWS

Cabinet

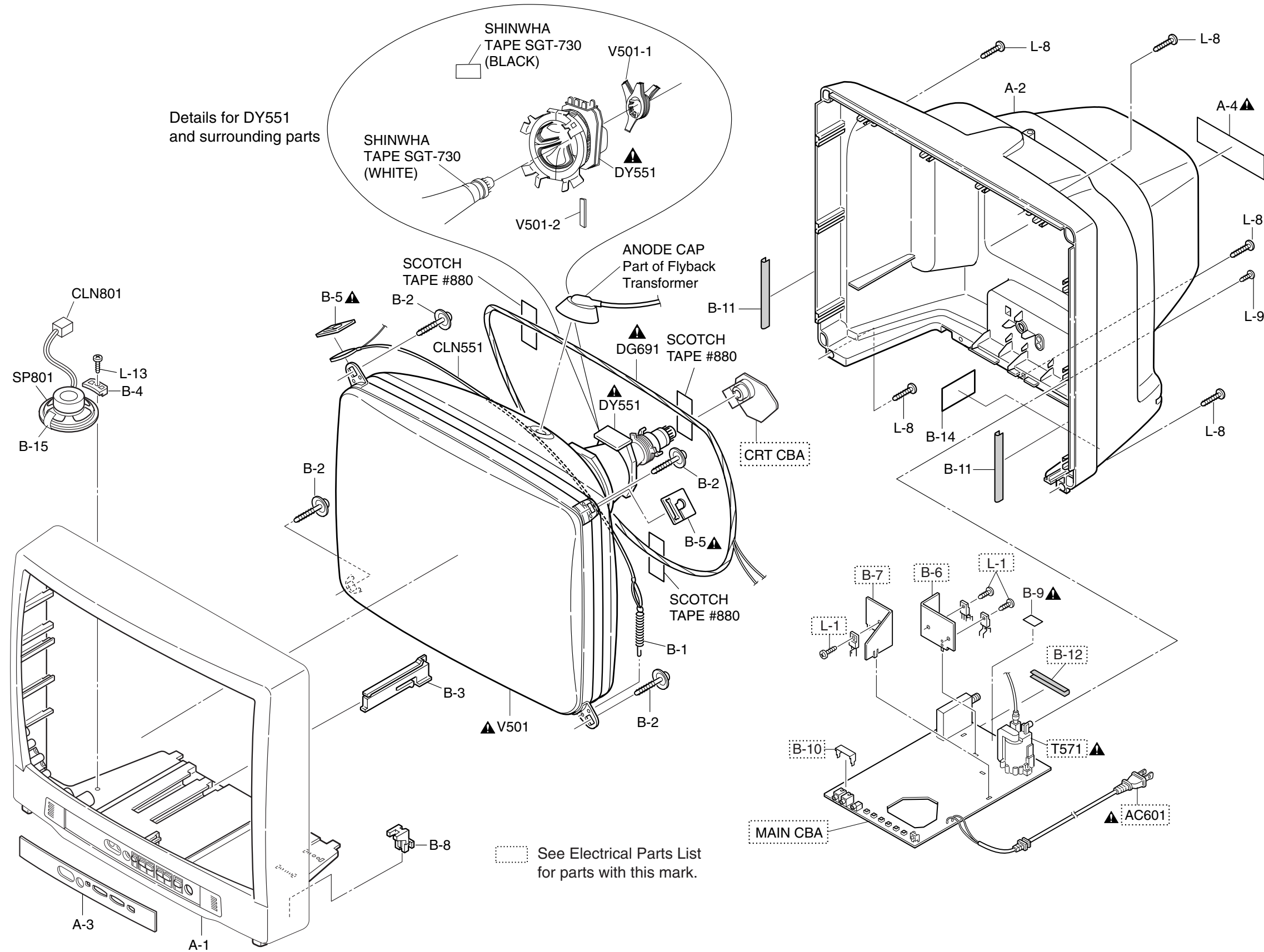

Packing

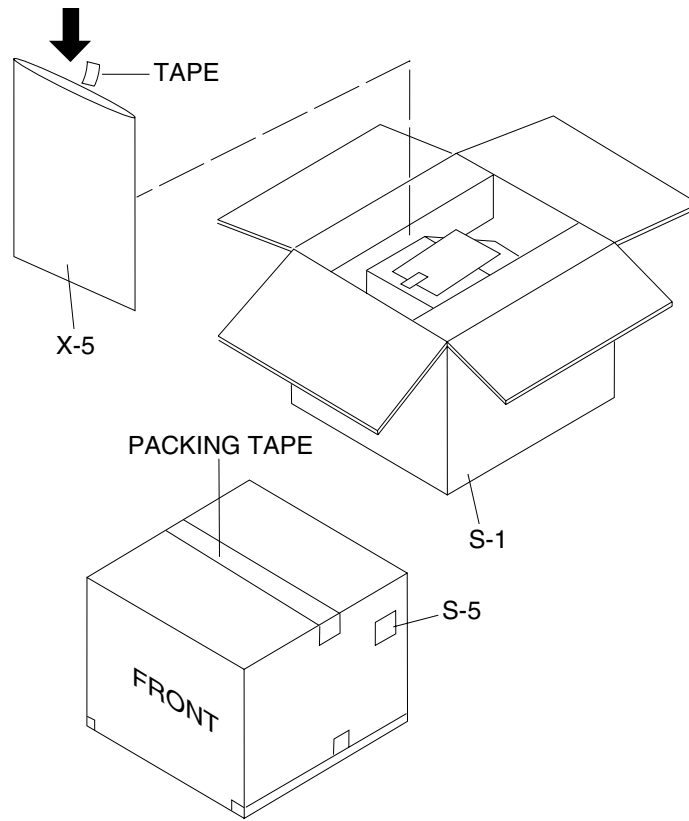
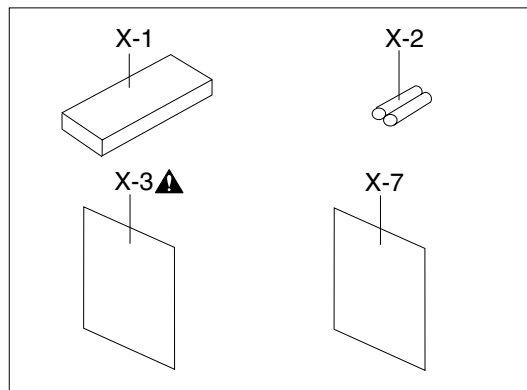
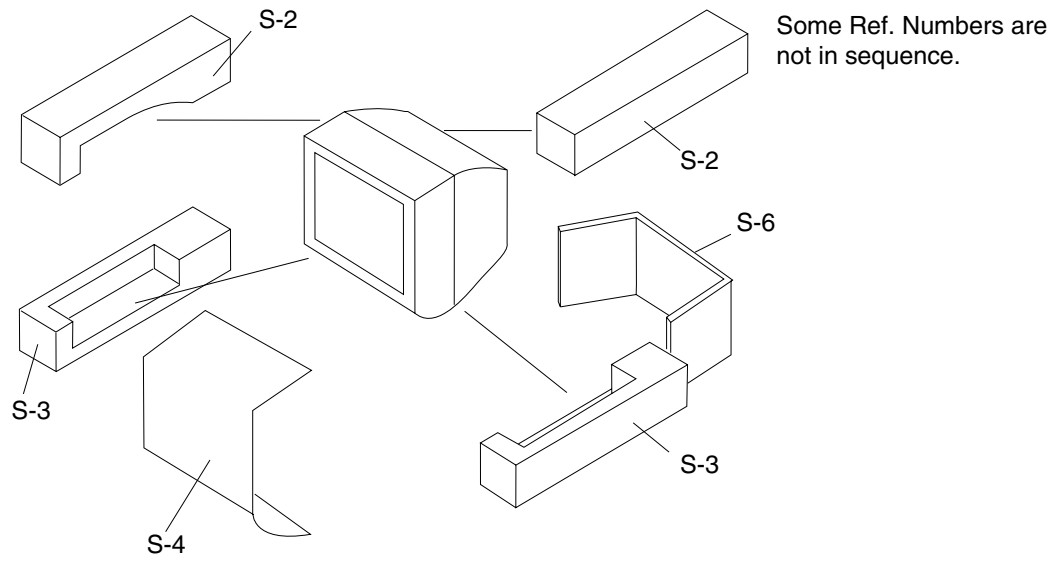

MECHANICAL PARTS LIST

PRODUCT SAFETY NOTE: Products marked with a **▲** have special characteristics important to safety. Before replacing any of these components, read carefully the product safety notice in this service manual. Don't degrade the safety of the product through improper servicing.

NOTE:

Parts that not assigned part numbers (-----) are not available.

Ref. No.	Description	Part No.
A-1	FRONT CABINET L1400UA	0EM000479
A-2	REAR CABINET L1400UA	0EM000482
A-3	CONTROL PLATE L6101UB	0EM301600
A-4▲	RATING LABEL L6102CC	-----
B-1	TENSION SPRING B0080B0:EM40808	26WH006
B-2	CRT MOUNTING SCREW B0030U1:K42419	8A00083
B-3	PCB HOLDER L1400UA	0EM301429
B-4	SPEAKER HOLDER L1400UA	0EM406026
B-5▲	DEGAUSS HOLDER L9800UA	0EM404845
B-8	AC CORD HOLDER L1400UA	0EM406104
B-9▲	CHASSIS NO. LABEL L6101UB	0EM406828
B-11	CLOTH L9800UA:95X15XT:0.5	0EM405041
B-14▲	CRITICAL PARTS WARNING LABEL B8007C3:EM41210	24LH199
B-15	CLOTH(10X30XT1.0) L9814UQ	0EM405137
CLN551	CRT GND WIRE CRT GND	WX1L7820-003
CLN801	WIRE ASSEMBLY SPEAKER WIRE(220MM)	WX1L7950-001
DG691▲	DEGAUSSING COIL AVDG014 or	LLBH00ZWR003
▲	DEGAUSSING COIL F-003	LLBH00ZTM003
L-8	SCREW, P-TIGHT 4X18 BIND HEAD +	GBMP4180
L-9	SCREW TAPPING M4X14	DBU14140
L-13	SCREW, P-TIGHT 3X12 BIND HEAD+	GBMP3120
SP801	SPEAKER S08F02B or	DSD0808XQ010
	SPEAKER J-F097-C5	DSD0808DCP01
PACKING		
S-1	CARTON L6102CC	0EM406887
S-2	STYRFOAM BOTTOM ASSEMBLY L6100UA	0EM406813
S-3	STYRFOAM TOP ASSEMBLY L9814UQ	0EM405094
S-4	SET SHEET L1400UA:1000X1500	0EM406680
S-5	SERIAL NO. LABEL L6102CC	0EM406886
S-6	HOLD PAD L6100UA	0EM406812
ACCESSORIES		
X-1	REMOCON UNIT 130/ERC001/N0132UD	N0132UD
X-2	DRY BATTERY R6P UM3 or	XB0M451GH001
	DRY BATTERY R6P/2S or	XB0M451T0001
	DRY BATTERY(SUNRISE) R6SSE/2S or	XB0M451MS002
	DRY BATTERY R6P(AR)2PX or	XB0M451HU002
	DRY BATTERY R6P(AR)2P X ICI	XB0M451HU003
X-3▲	OWNER'S MANUAL(E)/(F) L6002CC:ENGLISH/ FRENCH	0EMN01879
X-5	POLYETHYLENE BAG F8626B5	Z325350
X-7▲	QUICK SETUP GUIDE L1004CE	0EMN01726

Ref. No.	Description	Part No.
Note:		
1. V501 (CRT) HAS COUPLE OF SUBSTITUTIONAL PARTS AND EACH PARTS ALSO HAS MATCHING COMBINATION WITH DY551. PLEASE SEE TABLE 1 FOR DETAILS OF MATCHING COMBINATION.		
2. DY551 (DEFLECTION YOKE) HAS MATCHING COMBINATION WITH V501. PLEASE SEE TABLE 1 FOR DETAILS OF MATCHING COMBINATION.		
CRT TYPE A		
DY551▲	DEFLECTION YOKE KDY3MDA84X or	LLBY00ZMS013
▲	DEFLECTION YOKE LLBY00ZSY006 or	LLBY00ZSY006
▲	DEFLECTION YOKE CDY-M2019F	LLBY00ZQS004
V501▲	CRT A48JLL90X or	TCRT190QS009
▲	CRT A48JLL90X(K)	TCRT190QS019
V501-1	C.P.MAGNET JH225-014	XM04000BV009
V501-2	WEDGE FT-00110W or	XV10000T4001
	WEDGE DB25SR	XV10000D9001
CRT TYPE B		
DY551▲	DEFLECTION YOKE KDY3MCB20X or	LLBY00ZMS016
▲	DEFLECTION YOKE 330P510A37	LLBY00ZTHA01
V501▲	CRT A48LGS30X	TCRT190THA01
V501-1	C.P.MAGNET JH225-014	XM04000BV009
V501-2	WEDGE FT-00110W or	XV10000T4001
	WEDGE DB25SR	XV10000D9001
CRT TYPE C		
DY551▲	DEFLECTION YOKE CDY-M2023F or	LLBY00ZQS005
▲	DEFLECTION YOKE LLBY00ZSY007	LLBY00ZSY007
V501▲	CRT A48LRH93X(W)	TCRT190P7002
V501-1	C.P.MAGNET JH225-014	XM04000BV009
V501-2	WEDGE FT-00110W or	XV10000T4001
	WEDGE DB25SR	XV10000D9001
CRT TYPE D		
DY551▲	DEFLECTION YOKE LLBY00ZSY008	LLBY00ZSY008
V501▲	CRT A48LVL095X	TCRT190MS011
V501-1	C.P.MAGNET JH225-014	XM04000BV009
V501-2	WEDGE FT-00110W or	XV10000T4001
	WEDGE DB25SR	XV10000D9001
CRT TYPE E		
V501▲	CRT A48AEY13X01 K	TCRT190CP043

Table 1 (V501 and DY551 Combination)

Note 1: Purity and Convergence Adjustments must be performed following CRT replacement. Refer to Electrical Adjustment Instructions.

Note 2: Please confirm CRT Type No. on the CRT Warning Label which is located on the CRT. Then See the Table 1 for V501 and DY551 combination chart. Please refer this CRT, Deflection Yoke combination chart for parts order.

V501: CRT Type No.	V501: CRT Part No.	DY551: Deflection Yoke Part No.
CRT A48JLL90X	TCRT190QS009	LLBY00ZMS013
		LLBY00ZSY006
		LLBY00ZQS004
CRT A48JLL90X(K)	TCRT190QS019	LLBY00ZMS013
		LLBY00ZSY006
		LLBY00ZQS004
CRT A48LGS30X	TCRT190THA01	LLBY00ZMS016
		LLBY00ZTHA01
CRT A48LRH93X(W)	TCRT190P7002	LLBY00ZQS005
		LLBY00ZSY007
CRT A48LVL095X	TCRT190MS011	LLBY00ZSY008
CRT A48AEY13X01 K	TCRT190CP043	-----

CRT Warning Label Location

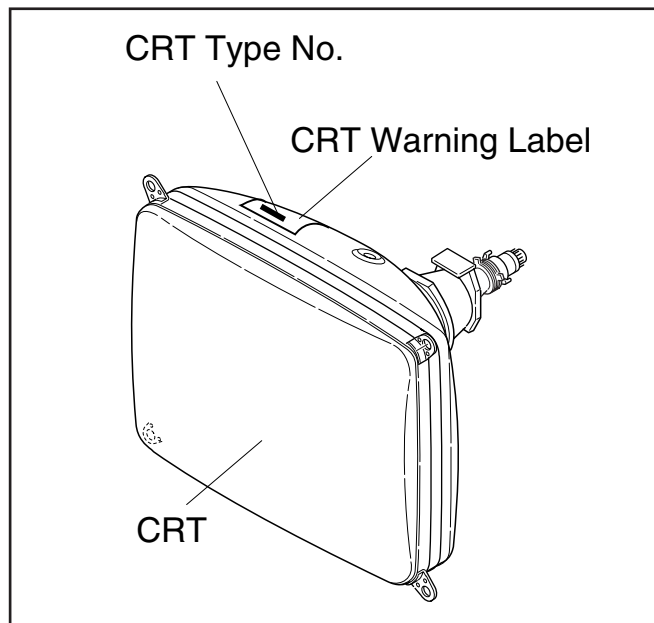

ELECTRICAL PARTS LIST

PRODUCT SAFETY NOTE: Products marked with a  have special characteristics important to safety. Before replacing any of these components, read carefully the product safety notice in this service manual. Don't degrade the safety of the product through improper servicing.

NOTES:

- Parts that not assigned part numbers (-----) are not available.
- Tolerance of Capacitors and Resistors are noted with the following symbols.

C.....±0.25% D.....±0.5% F.....±1%
 G.....±2% J.....±5% K.....±10%
 M.....±20% N.....±30% Z.....+80/-20%

MMA CBA

Ref. No.	Description	Part No.
	MMA-355 CBA Consists of the following	0ESA04562
	MAIN CBA	-----
	CRT CBA	-----

MAIN CBA

Ref. No.	Description	Part No.
	MAIN CBA Consists of the following	-----
CAPACITORS		
C5	ELECTROLYTIC CAP. 100µF/10V M or ELECTROLYTIC CAP. 100µF/10V M	CE1AMASTL101 CE1AMASDL101
C6	ELECTROLYTIC CAP. 4.7µF/50V M or ELECTROLYTIC CAP. 4.7µF/50V M	CE1JMASTL4R7 CE1JMASDL4R7
C125	CHIP CERAMIC CAP. B K 0.01µF/50V	CHD1JKB0B103
C126	CHIP CERAMIC CAP. B K 0.01µF/50V	CHD1JKB0B103
C127	CHIP CERAMIC CAP. F Z 0.1µF/25V	CHD1EZB0F104
C135	PCB JUMPER D0.6-P5.0	JW5.0T
C141	CHIP CERAMIC CAP. B K 0.01µF/50V	CHD1JKB0B103
C142	ELECTROLYTIC CAP. 100µF/10V M or ELECTROLYTIC CAP. 100µF/10V M	CE1AMASTL101 CE1AMASDL101
C151	CERAMIC CAP.(AX) F Z 0.01µF/25V	CDA1EZT0F103
C152	CHIP CERAMIC CAP. CH J 220pF/50V	CHD1JJBCH221
C153	CHIP CERAMIC CAP. CH J 220pF/50V	CHD1JJBCH221
C155	ELECTROLYTIC CAP. 47µF/16V M or ELECTROLYTIC CAP. 47µF/16V M	CE1CMASSTL470 CE1CMASDL470
C161	CERAMIC CAP.(AX) B K 0.015µF/50V	CA1J153TU011
C162	CHIP CERAMIC CAP. CH J 220pF/50V	CHD1JJBCH221
C163	ELECTROLYTIC CAP. 0.1µF/50V M or ELECTROLYTIC CAP. 0.1µF/50V M or ELECTROLYTIC CAP. 0.1µF/50V M	CE1JMASTLR10 CE1JMASDLR10 CE1JMASDL0R1
C164	FILM CAP.(P) 0.001µF/50V J or FILM CAP.(P) 0.001µF/50V J	CMA1JJS00102 CA1J102MS029
C165	CHIP CERAMIC CAP. B K 1000pF/50V	CHD1JKB0B102
C171	CERAMIC CAP.(AX) B K 220pF/50V	CCA1JKT0B221
C301	CERAMIC CAP.(AX) F Z 0.1µF/50V or	CA1J104TU014

Ref. No.	Description	Part No.
	CERAMIC CAP.(AX) F Z 0.1µF/50V	CCA1JZT0F104
C302	ELECTROLYTIC CAP. 220µF/10V M or ELECTROLYTIC CAP. 220µF/10V M	CE1AMASTL221 CE1AMASDL221
C303	FILM CAP.(P) 0.1µF/50V J or FILM CAP.(P) 0.1µF/50V J	CMA1JJS00104 CA1J104MS029
C304	CHIP CERAMIC CAP. B K 0.01µF/50V	CHD1JKB0B103
C308	CERAMIC CAP.(AX) B K 0.01µF/50V	CA1J103TU011
C309	ELECTROLYTIC CAP. 1µF/50V M or ELECTROLYTIC CAP. 1µF/50V M or ELECTROLYTIC CAP. 1µF/50V M	CE1JMASTL1R0 CE1JMASDL1R0 CE1JMASDL010
C313	ELECTROLYTIC CAP. 1000µF/10V M(VR) or ELECTROLYTIC CAP. 1000µF/10V M or ELECTROLYTIC CAP. 1000µF/10V M	CE1AMZNTL102 CE1AMZNDL102 CE1AMZADL102
C321	CHIP CERAMIC CAP. B K 0.01µF/50V	CHD1JKB0B103
C322	CERAMIC CAP.(AX) F Z 0.01µF/25V	CDA1EZT0F103
C331	ELECTROLYTIC CAP. 47µF/16V M or ELECTROLYTIC CAP. 47µF/16V M	CE1CMASSTL470 CE1CMASDL470
C332	CHIP CERAMIC CAP. B K 1000pF/50V	CHD1JKB0B102
C334	ELECTROLYTIC CAP. 4.7µF/50V M or ELECTROLYTIC CAP. 4.7µF/50V M	CE1JMASTL4R7 CE1JMASDL4R7
C335	CHIP CERAMIC CAP. F Z 0.1µF/25V	CHD1EZB0F104
C341	ELECTROLYTIC CAP. 1µF/50V M or ELECTROLYTIC CAP. 1µF/50V M or ELECTROLYTIC CAP. 1µF/50V M	CE1JMASTL1R0 CE1JMASDL1R0 CE1JMASDL010
C342	CHIP CERAMIC CAP. F Z 0.1µF/25V	CHD1EZB0F104
C344	CHIP CERAMIC CAP. B K 1000pF/50V	CHD1JKB0B102
C345	CHIP CERAMIC CAP. B K 0.015µF/50V	CHD1JKB0B153
C346	ELECTROLYTIC CAP. 1µF/50V M or ELECTROLYTIC CAP. 1µF/50V M or ELECTROLYTIC CAP. 1µF/50V M	CE1JMASTL1R0 CE1JMASDL1R0 CE1JMASDL010
C348	ELECTROLYTIC CAP. 0.1µF/50V M or ELECTROLYTIC CAP. 0.1µF/50V M or ELECTROLYTIC CAP. 0.1µF/50V M	CE1JMASTLR10 CE1JMASDLR10 CE1JMASDL0R1
C351	ELECTROLYTIC CAP. 100µF/10V M or ELECTROLYTIC CAP. 100µF/10V M	CE1AMASTL101 CE1AMASDL101
C353	ELECTROLYTIC CAP. 10µF/50V M or ELECTROLYTIC CAP. 10µF/50V M	CE1JMASTL100 CE1JMASDL100
C354	ELECTROLYTIC CAP. 10µF/50V M or ELECTROLYTIC CAP. 10µF/50V M	CE1JMASTL100 CE1JMASDL100
C355	CHIP CERAMIC CAP. B K 0.01µF/50V	CHD1JKB0B103
C356	ELECTROLYTIC CAP. 470µF/10V M or ELECTROLYTIC CAP. 470µF/10V M	CE1AMASTL471 CE1AMASDL471
C358	ELECTROLYTIC CAP. 0.47µF/50V M or ELECTROLYTIC CAP. 0.47µF/50V M	CE1JMASTLR47 CE1JMASDLR47
C361	ELECTROLYTIC CAP. 1µF/50V M or ELECTROLYTIC CAP. 1µF/50V M or ELECTROLYTIC CAP. 1µF/50V M	CE1JMASTL1R0 CE1JMASDL1R0 CE1JMASDL010
C364	ELECTROLYTIC CAP. 2.2µF/50V M or ELECTROLYTIC CAP. 2.2µF/50V M	CE1JMASTL2R2 CE1JMASDL2R2
C371	CERAMIC CAP.(AX) SL J 47pF/50V	CCA1JJTSL470
C372	CERAMIC CAP.(AX) SL J 47pF/50V	CCA1JJTSL470
C374	ELECTROLYTIC CAP. 2.2µF/50V M LL or ELECTROLYTIC CAP. 2.2µF/50V LL	CE1JMASLL2R2 CE1JMASLH2R2
C376	PCB JUMPER D0.6-P5.0	JW5.0T
C377	CERAMIC CAP.(AX) X K 3900pF/16V	CDA1CKT0X392
C381	CHIP CERAMIC CAP. F Z 0.1µF/25V	CHD1EZB0F104
C382	CHIP CERAMIC CAP. B K 0.01µF/50V	CHD1JKB0B103

Ref. No.	Description	Part No.
C384	CERAMIC CAP.(AX) CH J 68pF/50V	CA1J680TU008
C385	ELECTROLYTIC CAP. 0.47μF/50V M or ELECTROLYTIC CAP. 0.47μF/50V M	CE1JMASTLR47 CE1JMASDLR47
C386	CHIP CERAMIC CAP. B K 0.047μF/50V or CHIP CERAMIC CAP. B K 0.047μF/25V	CHD1JKB0B473 CHD1EKB0B473
C387	CERAMIC CAP.(AX) B K 0.047μF/50V	CA1J473TU011
C391	CERAMIC CAP.(AX) F Z 0.1μF/50V or CERAMIC CAP.(AX) F Z 0.1μF/50V	CA1J104TU014 CCA1JZT0F104
C551	ELECTROLYTIC CAP. 47μF/35V M or ELECTROLYTIC CAP. 47μF/35V M	CE1GMASL470 CE1GMASDL470
C552	FILM CAP.(P) 0.1μF/50V J or FILM CAP.(P) 0.1μF/50V J	CMA1JJS00104 CA1J104MS029
C554	ELECTROLYTIC CAP. 470μF/35V M(VR) or ELECTROLYTIC CAP. 470μF/35V M or ELECTROLYTIC CAP. 470μF/35V M	CE1GMZNTL471 CE1GMZNDL471 CE1GMZADL471
C562	ELECTROLYTIC CAP. 2.2μF/50V M LL or ELECTROLYTIC CAP. 2.2μF/50V LL	CE1JMASLL2R2 CE1JMASLH2R2
C566	ELECTROLYTIC CAP. 1000μF/25V M or ELECTROLYTIC CAP. 1000μF/25V M or ELECTROLYTIC CAP. 1000μF/25V M	CE1EMZNTL102 CE1EMZPDL102 CE1EMZADL102
C568	ELECTROLYTIC CAP. 3.3μF/50V M or ELECTROLYTIC CAP. 3.3μF/50V M	CE1JMASTL3R3 CE1JMASDL3R3
C571▲	PP CAP. 0.47μF/250V J or ▲ P.P.CAP 0.47μF/200 J	CT2E474MS041 CA2D474VC012
C574▲	ELECTROLYTIC CAP. 4.7μF/250V M	CE2EMASDL4R7
C577	ELECTROLYTIC CAP. 47μF/35V M or ELECTROLYTIC CAP. 47μF/35V M	CE1GMASL470 CE1GMASDL470
C578	FILM CAP.(P) 0.01μF/50V J or FILM CAP.(P) 0.01μF/50V J	CMA1JJS00103 CA1J103MS029
C580▲	PP CAP. 0.01μF/1.6KV J or ▲ PP CAP. 0.01μF/1.6KV J or ▲ P.P.CAP 0.01μF/1.6KV J	CT3C103MS039 CBH3CJQ00103 CA3C103VC011
C581▲	CERAMIC CAP. LB 1000pF/2KV or ▲ CERAMIC CAP. BN 1000pF/2KV or ▲ CERAMIC CAP. 1000pF/2KV	CA3D102KG004 CCD3DKA0B102 CA3D102PAN04
C584▲	ELECTROLYTIC CAP. 1μF/160V M or ▲ ELECTROLYTIC CAP. 1μF/160V M	CE2CMASL1R0 CE2CMASDL1R0
C594▲	ELECTROLYTIC CAP. 10μF/50V M or ▲ ELECTROLYTIC CAP. 10μF/50V M	CE1JMASTL100 CE1JMASDL100
C601▲	METALLIZED FILM CAP. 0.1μF/250V or ▲ FILM CAP.(MP) 0.1μF/250V K	CT2E104MS037 CT2E104DC011
C605	CERAMIC CAP. F Z 0.01μF/500V or CERAMIC CAP. 0.01μF/AC250V	CCD2JZD0F103 CCD2EZA0F103
C606	CERAMIC CAP. F Z 0.01μF/500V or CERAMIC CAP. 0.01μF/AC250V	CCD2JZD0F103 CCD2EZA0F103
C609	CERAMIC CAP. B K 1000pF/2KV or CERAMIC CAP. B K 1000pF/2KV or CERAMIC CAP. B K 1000pF/2KV	CCD3DKD0B102 CCD3DKP0B102 CA3D102MR030
C610▲	ELECTROLYTIC CAP. 220μF/200V or ▲ ELECTROLYTIC CAP. 220μF/200V SL X	CA2D221NC088 CA2D221S6003
C611	FILM CAP.(P) 0.068μF/50V J or FILM CAP.(P) 0.068μF/50V J	CMA1JJS00683 CA1J683MS029
C612	CERAMIC CAP. LB 330pF/2KV or CERAMIC CAP. BN 330pF/2KV or CERAMIC CAP. 330pF/2KV	CA3D331KG004 CCD3DKA0B331 CA3D331PAN04
C616	FILM CAP.(P) 0.056μF/50V J or FILM CAP.(P) 0.056μF/50V J	CMA1JJS00563 CA1J563MS029
C617	CERAMIC CAP.(AX) B K 330pF/50V	CCA1JKT0B331
If C643 is 4700pF, then JS642 (PCB JUMPER) is used.		
C643▲	SAFETY CAP. 4700pF/250V KX	CA2E472MR050
JS642	PCB JUMPER D0.6-P7.5	JW7.5T

Ref. No.	Description	Part No.
If C642 is 0.01μF, then C643 is 0.01μF.		
C642▲	SAFETY CAP. 10000pF/250V or ▲ SAFETY CAP. F M 0.01μF/250V or ▲ CERAMIC CAP. 0.01μF F CS	CCG2EMA0F103 CCG2EMP0F103 CCG2HMNOF103
C643▲	SAFETY CAP. 10000pF/250V or ▲ SAFETY CAP. F M 0.01μF/250V or ▲ CERAMIC CAP. 0.01μF F CS	CCG2EMA0F103 CCG2EMP0F103 CCG2HMNOF103
C650	CERAMIC CAP. LB 470pF/2KV or CERAMIC CAP. BN 470pF/2KV or CERAMIC CAP. 470pF/2KV	CA3D471KG004 CCD3DKA0B471 CA3D471PAN04
C651	CERAMIC CAP. LB 470pF/2KV or CERAMIC CAP. BN 470pF/2KV or CERAMIC CAP. 470pF/2KV	CA3D471KG004 CCD3DKA0B471 CA3D471PAN04
C654▲	ELECTROLYTIC CAP. 1μF/50V M or ▲ ELECTROLYTIC CAP. 1μF/50V M or ▲ ELECTROLYTIC CAP. 1μF/50V M	CE1JMASTL1R0 CE1JMASDL1R0 CE1JMASDL010
C656▲	ELECTROLYTIC CAP. 100μF/160V M or ▲ ELECTROLYTIC CAP. 100μF/160V M	CE2CMZPTL101 CE2CMZNDL101
C657	ELECTROLYTIC CAP. 1000μF/35V M or ELECTROLYTIC CAP. 1000μF/35V M or ELECTROLYTIC CAP. 1000μF/35V M	CE1GMZNTL102 CE1GMZNDL102 CE1GMZADL102
C658▲	ELECTROLYTIC CAP. 1000μF/16V M(VR/HC) or ▲ ELECTROLYTIC CAP. 1000μF/16V M or ▲ ELECTROLYTIC CAP. 1000μF/16V M	CE1CMZNTL102 CE1CMZPDL102 CE1CMZADL102
C667	ELECTROLYTIC CAP. 1μF/50V M or ELECTROLYTIC CAP. 1μF/50V M or ELECTROLYTIC CAP. 1μF/50V M	CE1JMASTL1R0 CE1JMASDL1R0 CE1JMASDL010
C681	ELECTROLYTIC CAP. 100μF/10V M or ELECTROLYTIC CAP. 100μF/10V M	CE1AMASTL101 CE1AMASDL101
C682	ELECTROLYTIC CAP. 100μF/10V M or ELECTROLYTIC CAP. 100μF/10V M	CE1AMASTL101 CE1AMASDL101
C683	ELECTROLYTIC CAP. 100μF/10V M or ELECTROLYTIC CAP. 100μF/10V M	CE1AMASTL101 CE1AMASDL101
C686	ELECTROLYTIC CAP. 33μF/16V M or ELECTROLYTIC CAP. 33μF/16V M	CE1CMASL330 CE1CMASDL330
C687	ELECTROLYTIC CAP. 100μF/10V M or ELECTROLYTIC CAP. 100μF/10V M	CE1AMASTL101 CE1AMASDL101
C692	ELECTROLYTIC CAP. 10μF/160V M or ELECTROLYTIC CAP. 10μF/160V M	CE2CMASL100 CE2CMASDL100
C701	CHIP CERAMIC CAP. CH J 100pF/50V	CHD1JJBCH101
C711	CERAMIC CAP.(AX) X K 2200pF/16V	CDA1CKT0X222
C805	ELECTROLYTIC CAP. 220μF/16V M or ELECTROLYTIC CAP. 220μF/16V M	CE1CMASL221 CE1CMASDL221
C811	ELECTROLYTIC CAP. 470μF/16V M or ELECTROLYTIC CAP. 470μF/16V M	CE1CMASL471 CE1CMASDL471
C821	CERAMIC CAP.(AX) X K 2700pF/16V	CDA1CKT0X272
C822	CHIP CERAMIC CAP. F Z 0.22μF/16V	CHD1CZB0F224
C823	CHIP CERAMIC CAP. F Z 0.47μF/10V or CHIP CERAMIC CAP. F Z 0.47μF/16V	CHD1AZB0F474 CHD1CZB0F474
CONNECTORS		
CN301	CONNECTOR BASE , 5P TUC-P05P-B1	J3TUA05TG001
CN571	CONNECTOR BASE , 5P TV-50P-05-V3 or CONNECTOR BASE , 5P RTB-1.5-5P	J3TVC05TG002 J3RTC05JG001
CN691	CONNECTOR BASE , 2P TV-50P-02-V3 or CONNECTOR BASE , 2P RTB-1.5-2P	J3TVC02TG002 J3RTC02JG001
CN801	STRAIGHT CONNECTOR BASE 00 8283 0212 00 000 or STRAIGHT PIN HEADER , 2P 173981-2	J383C02UG002 1770258
DIODES		
D101	SWITCHING DIODE 1SS133(T-77) or SWITCHING DIODE 1N4148	QDTZ001SS133 NDTZ001N4148

Ref. No.	Description	Part No.
D102	SWITCHING DIODE 1SS133(T-77) or	QDTZ001SS133
	SWITCHING DIODE 1N4148	NDTZ001N4148
D125	ZENER DIODE MTZJT-775.6B	QDTB00MTZJ5R6
D126	ZENER DIODE MTZJT-775.1B	QDTB00MTZJ5R1
D132	ZENER DIODE MTZJT-775.1B	QDTB00MTZJ5R1
D141	ZENER DIODE MTZJT-775.6B	QDTB00MTZJ5R6
D181▲	SWITCHING DIODE 1SS133(T-77) or	QDTZ001SS133
▲	SWITCHING DIODE 1N4148	NDTZ001N4148
D301	ZENER DIODE MTZJT-775.6B	QDTB00MTZJ5R6
D306	SWITCHING DIODE 1SS133(T-77) or	QDTZ001SS133
	SWITCHING DIODE 1N4148	NDTZ001N4148
D307	SWITCHING DIODE 1SS133(T-77) or	QDTZ001SS133
	SWITCHING DIODE 1N4148	NDTZ001N4148
D314	SWITCHING DIODE 1SS133(T-77) or	QDTZ001SS133
	SWITCHING DIODE 1N4148	NDTZ001N4148
D315	SWITCHING DIODE 1SS133(T-77) or	QDTZ001SS133
	SWITCHING DIODE 1N4148	NDTZ001N4148
D316	SWITCHING DIODE 1SS133(T-77) or	QDTZ001SS133
	SWITCHING DIODE 1N4148	NDTZ001N4148
D321	ZENER DIODE MTZJT-775.6B	QDTB00MTZJ5R6
D351	ZENER DIODE MTZJT-779.1B	QDTB00MTZJ9R1
D354	SWITCHING DIODE 1SS133(T-77) or	QDTZ001SS133
	SWITCHING DIODE 1N4148	NDTZ001N4148
D376	ZENER DIODE MTZJT-779.1B	QDTB00MTZJ9R1
D381	ZENER DIODE MTZJT-775.6B	QDTB00MTZJ5R6
D391	ZENER DIODE MTZJT-775.6B	QDTB00MTZJ5R6
D392	ZENER DIODE MTZJT-775.6B	QDTB00MTZJ5R6
D551	DIODE 1N5397-B or	NDLZ001N5397
	RECTIFIER DIODE ERB12-06	QDQZ0ERB1206
D568▲	SWITCHING DIODE 1SS133(T-77) or	QDTZ001SS133
▲	SWITCHING DIODE 1N4148	NDTZ001N4148
D569▲	ZENER DIODE MTZJT-7720B	QDTB00MTZJ20
D571	DIODE FR104-B or	NDLZ000FR104
	RECTIFIER DIODE ERA22-02 or	QDPZ0ERA2202
	RECTIFIER DIODE 10ELS2	QDQZ0010ELS2
D572▲	DIODE FR104-B or	NDLZ000FR104
▲	RECTIFIER DIODE ERA22-02 or	QDPZ0ERA2202
▲	RECTIFIER DIODE 10ELS2	QDQZ0010ELS2
D573▲	DIODE FR104-B or	NDLZ000FR104
▲	RECTIFIER DIODE ERA22-02 or	QDPZ0ERA2202
▲	RECTIFIER DIODE 10ELS2	QDQZ0010ELS2
D584▲	SWITCHING DIODE 1SS133(T-77) or	QDTZ001SS133
▲	SWITCHING DIODE 1N4148	NDTZ001N4148
D593▲	ZENER DIODE MTZJT-7736B	QDTB00MTZJ36
D595	SWITCHING DIODE 1SS133(T-77) or	QDTZ001SS133
	SWITCHING DIODE 1N4148	NDTZ001N4148
D597	ZENER DIODE MTZJT-776.8B	QDTB00MTZJ6R8
D605▲	DIODE 1N5397-B or	NDLZ001N5397
▲	RECTIFIER DIODE ERB12-06	QDQZ0ERB1206
D606▲	DIODE 1N5397-B or	NDLZ001N5397
▲	RECTIFIER DIODE ERB12-06	QDQZ0ERB1206
D607▲	DIODE 1N5397-B or	NDLZ001N5397
▲	RECTIFIER DIODE ERB12-06	QDQZ0ERB1206
D608▲	DIODE 1N5397-B or	NDLZ001N5397
▲	RECTIFIER DIODE ERB12-06	QDQZ0ERB1206
D611▲	ZENER DIODE MTZJT-7715B	QDTB00MTZJ15
D613▲	ZENER DIODE MTZJT-7718B	QDTB00MTZJ18
D615▲	SWITCHING DIODE 1N4148 T-77	QDTZ001N4148
D621	ZENER DIODE DZ-3.0BSBT265	NDTB00DZ3R0BS
D641	BEAD INDUCTORS FBR07HA121TB-00	LLBF00ZTU021
D642	SWITCHING DIODE 1SS133(T-77) or	QDTZ001SS133

Ref. No.	Description	Part No.
	SWITCHING DIODE 1N4148	NDTZ001N4148
D651▲	FAST RECOVERY DIODE CA201-4 or	QDWZ00CA2014
▲	RECOVERY DIODE ERC18-04 or	QDZZ0ERC1804
▲	FAST RECOVERY DIODE ERC25-06	QDQZ0ERC2506
D652▲	DIODE FR154 or	NDLZ000FR154
▲	FAST RECOVERY DIODE ERB44-02	QDPZ0ERB4402
D653▲	DIODE FR154 or	NDLZ000FR154
▲	FAST RECOVERY DIODE ERB44-02	QDPZ0ERB4402
D654▲	SWITCHING DIODE 1SS133(T-77) or	QDTZ001SS133
▲	SWITCHING DIODE 1N4148	NDTZ001N4148
D657▲	DIODE 1ZC36	QDQZ0001ZC36
D660	SWITCHING DIODE 1SS133(T-77) or	QDTZ001SS133
	SWITCHING DIODE 1N4148	NDTZ001N4148
D661▲	SWITCHING DIODE 1SS133(T-77) or	QDTZ001SS133
▲	SWITCHING DIODE 1N4148	NDTZ001N4148
D662▲	ZENER DIODE MTZJT-776.8B	QDTB00MTZJ6R8
D666	ZENER DIODE MTZJT-7736B	QDTB00MTZJ36
D671▲	SWITCHING DIODE 1SS133(T-77) or	QDTZ001SS133
▲	SWITCHING DIODE 1N4148	NDTZ001N4148
D672	PCB JUMPER D0.6-P5.0	JW5.0T
D673	SWITCHING DIODE 1SS133(T-77) or	QDTZ001SS133
	SWITCHING DIODE 1N4148	NDTZ001N4148
D681	CARBON RES. 1/4W J 10k Ω or	RCX4JATZ0103
	CARBON RES. 1/6W J 10k Ω	RCX6JATZ0103
D682▲	ZENER DIODE MTZJT-775.6B	QDTB00MTZJ5R6
D691▲	SWITCHING DIODE 1SS133(T-77) or	QDTZ001SS133
▲	SWITCHING DIODE 1N4148	NDTZ001N4148
D694	PCB JUMPER D0.6-P5.0	JW5.0T
D696	SWITCHING DIODE 1SS133(T-77) or	QDTZ001SS133
	SWITCHING DIODE 1N4148	NDTZ001N4148
D811▲	SWITCHING DIODE 1SS133(T-77) or	QDTZ001SS133
▲	SWITCHING DIODE 1N4148	NDTZ001N4148
D831	SWITCHING DIODE 1SS133(T-77) or	QDTZ001SS133
	SWITCHING DIODE 1N4148	NDTZ001N4148
ICS		
IC111▲	IC M37150M8-050FP	QSZAA0SMB088
IC151	IC:MEMORY AT24C01A-10SC or	NSMMA0SAZ011
	IC:(EEPROM) M24C01-MN6 or	NSMMA0SSS027
	IC:MEMORY BR24C01AF-W or	QSMBA0SRM002
	IC:MEMORY BR24C01AF or	QSMMA0SRM002
	IC:MEMORY S524C20D21	NSZBA0SSM028
IC333▲	IC:CHROMA/IF 1 CHIP M61210FP-R60* or	QSZAA0RMB086
▲	IC:CHROMA/IF 1 CHIP M61210FP-R61	QSZAB0RMB086
IC551▲	VERTICAL OUTPUT IC LA78040A or	QSBBA0SSY003
▲	VERTICAL OUTPUT IC AN5522	QSZBA0SMS002
IC601▲	PHOTOCOUPLER LTV-817B-F or	NPEB0LTV817F
▲	PHOTOCOUPLER LTV-817C-F	NPEC0LTV817F
IC801	AUDIO AMP LA4224	QSZAA0SSY005
COILS		
L5	INDUCTOR 22μH-K-5FT or	LLARKBSTU220
	INDUCTOR 22μH-K	LLARKDQKA220
L11	PCB JUMPER D0.6-P5.0	JW5.0T
L15	INDUCTOR 1.2μH-J-26T or	LLAXJATTU1R2
	INDUCTOR 1.2μH-K-26T	LLAXKDTKA1R2
L121	INDUCTOR 22μH-K-5FT or	LLARKBSTU220
	INDUCTOR 22μH-K	LLARKDQKA220
L302	PCB JUMPER D0.6-P5.0	JW5.0T
L351	INDUCTOR 100μH-K-5FT or	LLARKBSTU101
	INDUCTOR 100μH-K	LLARKDQKA101
L356	INDUCTOR 12μH-J-26T or	LLAXJATTU120

Ref. No.	Description	Part No.
	INDUCTOR 12 μ H-K-26T	LLAXKDTKA120
L371	INDUCTOR 15 μ H-J-26T or	LLAXJATTU150
	INDUCTOR 15 μ H-K-26T	LLAXKDTKA150
L383	CARBON RES. 1/4W J 82 Ω or	RCX4JATZ0820
	CARBON RES. 1/6W J 82 Ω	RCX6JATZ0820
L601▲	LINE FILTER TLF12UA302W1R0 or	LLBG00ZTU025
▲	LINE FILTER 5.0MH 6Y075 or	LLBG00ZKT004
▲	LINE FILTER LF005 or	LLBG00ZLH001
▲	LINE FILTER UU10.5-A or	LLBG00ZY2008
▲	LINE FILTER SA-91213B or	LLBG00ZSA002
▲	LINE FILTER TLF14CB3321R0	LLBG00ZTU012
L692	CHOKE COIL 47 μ H-K or	LLBD00PKV007
	POT COIL 47 μ H K	LLBD**DMM001
TRANSISTORS		
Q121	TRANSISTOR 2SC2785(F) or	QQSF02SC2785
	TRANSISTOR 2SC2785(H) or	QQSH02SC2785
	TRANSISTOR 2SC2785(J) or	QQSJ02SC2785
	TRANSISTOR KTC3199(GR) or	NQS10KTC3199
	TRANSISTOR KTC3198(GR) or	NQS40KTC3198
	TRANSISTOR 2SC1815-GR(TPE2)	QQS102SC1815
Q351	TRANSISTOR 2SC2785(F) or	QQSF02SC2785
	TRANSISTOR 2SC2785(H) or	QQSH02SC2785
	TRANSISTOR 2SC2785(J) or	QQSJ02SC2785
	TRANSISTOR KTC3199(GR) or	NQS10KTC3199
	TRANSISTOR KTC3198(GR) or	NQS40KTC3198
	TRANSISTOR 2SC1815-GR(TPE2)	QQS102SC1815
Q571▲	TRANSISTOR 2SD2627LS-FEC-YB11 or	QQZZ02SD2627
▲	TRANSISTOR 2SD2629-YB	QQZZ02SD2629
Q572	TRANSISTOR 2SC1627Y-TPE2	QQSY02SC1627
Q601▲	MOS FET 2SK2662	QF5Z02SK2662
Q602▲	TRANSISTOR 2SC2120-O-TPE2 or	QQS002SC2120
▲	TRANSISTOR 2SC2120-Y(TPE2)	QQSY02SC2120
Q662▲	TRANSISTOR 2SC2785(F) or	QQSF02SC2785
▲	TRANSISTOR 2SC2785(H) or	QQSH02SC2785
▲	TRANSISTOR 2SC2785(J) or	QQSJ02SC2785
▲	TRANSISTOR KTC3199(GR) or	NQS10KTC3199
▲	TRANSISTOR KTC3198(GR) or	NQS40KTC3198
▲	TRANSISTOR 2SC1815-GR(TPE2)	QQS102SC1815
Q671▲	TRANSISTOR 2SA1175(F) or	QQSF02SA1175
▲	TRANSISTOR KTA1267(GR) or	NQS10KTA1267
▲	TRANSISTOR KTA1266(GR) or	NQS40KTA1266
▲	TRANSISTOR 2SA1015-GR(TPE2)	QQS102SA1015
Q675	TRANSISTOR 2SC2785(F) or	QQSF02SC2785
	TRANSISTOR 2SC2785(H) or	QQSH02SC2785
	TRANSISTOR 2SC2785(J) or	QQSJ02SC2785
	TRANSISTOR KTC3199(GR) or	NQS10KTC3199
	TRANSISTOR KTC3198(GR) or	NQS40KTC3198
	TRANSISTOR 2SC1815-GR(TPE2)	QQS102SC1815
Q676	RES. BUILT-IN TRANSISTOR BA1F4M-T or	QQSZ00BA1F4M
	RES. BUILT-IN TRANSISTOR KRC103M	NQSZ0KRC103M
Q681	TRANSISTOR 2SC2120-O-TPE2 or	QQS002SC2120
	TRANSISTOR 2SC2120-Y(TPE2) or	QQSY02SC2120
	TRANSISTOR KTC3203(Y)	NQSY0KTC3203
Q682	TRANSISTOR 2SC2120-O-TPE2 or	QQS002SC2120
	TRANSISTOR 2SC2120-Y(TPE2) or	QQSY02SC2120
	TRANSISTOR KTC3203(Y)	NQSY0KTC3203
Q683	TRANSISTOR 2SC2120-O-TPE2 or	QQS002SC2120
	TRANSISTOR 2SC2120-Y(TPE2) or	QQSY02SC2120
	TRANSISTOR KTC3203(Y)	NQSY0KTC3203
Q696	RES. BUILT-IN TRANSISTOR BA1F4M-T or	QQSZ00BA1F4M

Ref. No.	Description	Part No.
	RES. BUILT-IN TRANSISTOR KRC103M	NQSZ0KRC103M
RESISTORS		
R11	CHIP RES.(1608) 1/10W J 100 Ω	RRXAJB5Z0101
R12	CHIP RES.(1608) 1/10W J 100 Ω	RRXAJB5Z0101
R102	CHIP RES.(1608) 1/10W J 2.2k Ω	RRXAJB5Z0222
R103	CHIP RES.(1608) 1/10W J 1.8k Ω	RRXAJB5Z0182
R104	CHIP RES.(1608) 1/10W J 3.3k Ω	RRXAJB5Z0332
R105	CHIP RES.(1608) 1/10W J 4.7k Ω	RRXAJB5Z0472
R106	CHIP RES.(1608) 1/10W J 8.2k Ω	RRXAJB5Z0822
R107	CHIP RES.(1608) 1/10W J 2.2k Ω	RRXAJB5Z0222
R108	CHIP RES. 1/10W J 0 Ω	RRXAJB5Z0000
R109	CHIP RES.(1608) 1/10W J 10k Ω	RRXAJB5Z0103
R110	CHIP RES.(1608) 1/10W J 10k Ω	RRXAJB5Z0103
R111	CARBON RES. 1/4W J 1k Ω or	RCX4JATZ0102
	CARBON RES. 1/6W J 1k Ω	RCX6JATZ0102
R121	CARBON RES. 1/4W J 100 Ω or	RCX4JATZ0101
	CARBON RES. 1/6W J 100 Ω	RCX6JATZ0101
R125	CHIP RES.(1608) 1/10W J 1k Ω	RRXAJB5Z0102
R126	CHIP RES.(1608) 1/10W J 220k Ω	RRXAJB5Z0224
R127	CHIP RES.(1608) 1/10W J 100k Ω	RRXAJB5Z0104
R128	CHIP RES.(1608) 1/10W J 100 Ω	RRXAJB5Z0101
R129	CHIP RES.(1608) 1/10W J 22k Ω	RRXAJB5Z0223
R132	CHIP RES. 1/10W J 0 Ω	RRXAJB5Z0000
R151	CHIP RES.(1608) 1/10W J 4.7k Ω	RRXAJB5Z0472
R152	CHIP RES.(1608) 1/10W J 4.7k Ω	RRXAJB5Z0472
R153	CHIP RES.(1608) 1/10W J 4.7k Ω	RRXAJB5Z0472
R155	CARBON RES. 1/4W J 100 Ω or	RCX4JATZ0101
	CARBON RES. 1/6W J 100 Ω	RCX6JATZ0101
R161	CHIP RES.(1608) 1/10W J 2.7k Ω	RRXAJB5Z0272
R162	CHIP RES.(1608) 1/10W J 1k Ω	RRXAJB5Z0102
R171	CHIP RES.(1608) 1/10W J 220 Ω	RRXAJB5Z0221
R305	CHIP RES.(1608) 1/10W J 1k Ω	RRXAJB5Z0102
R306	CHIP RES.(1608) 1/10W J 82k Ω	RRXAJB5Z0823
R308	CHIP RES.(1608) 1/10W J 220k Ω	RRXAJB5Z0224
R309	CHIP RES.(1608) 1/10W J 6.8k Ω	RRXAJB5Z0682
R310	CHIP RES.(1608) 1/10W J 10k Ω	RRXAJB5Z0103
R311	CHIP RES.(1608) 1/10W J 2.7k Ω	RRXAJB5Z0272
R314	CHIP RES.(1608) 1/10W J 100 Ω	RRXAJB5Z0101
R315	CHIP RES.(1608) 1/10W J 100 Ω	RRXAJB5Z0101
R316	CHIP RES.(1608) 1/10W J 100 Ω	RRXAJB5Z0101
R317	CHIP RES.(1608) 1/10W J 2.2k Ω	RRXAJB5Z0222
R318	CHIP RES.(1608) 1/10W J 2.2k Ω	RRXAJB5Z0222
R319	CHIP RES.(1608) 1/10W J 2.2k Ω	RRXAJB5Z0222
R321	CHIP RES.(1608) 1/10W J 1M Ω	RRXAJB5Z0105
R323	CHIP RES.(1608) 1/10W J 47k Ω	RRXAJB5Z0473
R324	CHIP RES.(1608) 1/10W J 100k Ω	RRXAJB5Z0104
R329	PCB JUMPER D0.6-P5.0	JW5.0T
R331	CHIP RES.(1608) 1/10W J 100 Ω	RRXAJB5Z0101
R333	CHIP RES.(1608) 1/10W J 10k Ω	RRXAJB5Z0103
R336	CHIP RES.(1608) 1/10W J 270k Ω	RRXAJB5Z0274
R337	CHIP RES. 1/10W J 0 Ω	RRXAJB5Z0000
R341	CHIP RES.(1608) 1/10W J 270k Ω	RRXAJB5Z0274
R342	CHIP RES.(1608) 1/10W J 150k Ω	RRXAJB5Z0154
R343	CHIP RES.(1608) 1/10W J 15k Ω	RRXAJB5Z0153
R346	CHIP RES.(1608) 1/10W J 6.8k Ω	RRXAJB5Z0682
R348	CHIP RES.(1608) 1/10W J 470 Ω	RRXAJB5Z0471
R353	CARBON RES. 1/4W J 2.2k Ω or	RCX4JATZ0222
	CARBON RES. 1/6W J 2.2k Ω	RCX6JATZ0222
R355	CHIP RES.(1608) 1/10W J 100 Ω	RRXAJB5Z0101
R373	CHIP RES.(1608) 1/10W J 10 Ω	RRXAJB5Z0100

Ref. No.	Description	Part No.
R374	CHIP RES.(1608) 1/10W J 15k Ω	RRXAJB5Z0153
R376	CHIP RES.(1608) 1/10W J 470 Ω	RRXAJB5Z0471
R380	CHIP RES.(1608) 1/10W J 100 Ω	RRXAJB5Z0101
R383	CHIP RES.(1608) 1/10W J 470 Ω	RRXAJB5Z0471
R384	CHIP RES.(1608) 1/10W J 220 Ω	RRXAJB5Z0221
R391	CHIP RES.(1608) 1/10W J 1k Ω	RRXAJB5Z0102
R392	CHIP RES.(1608) 1/10W J 100 Ω	RRXAJB5Z0101
R393	CHIP RES.(1608) 1/10W J 100 Ω	RRXAJB5Z0101
R394	CHIP RES.(1608) 1/10W J 100 Ω	RRXAJB5Z0101
R551	CARBON RES. 1/4W J 4.7 Ω or CARBON RES. 1/6W J 4.7 Ω	RCX4JATZ04R7 RCX6JATZ04R7
R555▲	METAL OXIDE FILM RES. 2W J 10 Ω or ▲ METAL OXIDE FILM RES. 2W J 10 Ω	RN02100ZU001 RN02100DP004
R556	CARBON RES. 1/4W J 1k Ω or CARBON RES. 1/6W J 1k Ω	RCX4JATZ0102 RCX6JATZ0102
R557	CARBON RES. 1/4W J 1k Ω or CARBON RES. 1/6W J 1k Ω	RCX4JATZ0102 RCX6JATZ0102
R558	CARBON RES. 1/4W J 3.3k Ω or CARBON RES. 1/6W J 3.3k Ω	RCX4JATZ0332 RCX6JATZ0332
R559	CARBON RES. 1/4W J 3.3k Ω or CARBON RES. 1/6W J 3.3k Ω	RCX4JATZ0332 RCX6JATZ0332
R561	CHIP RES.(1608) 1/10W J 470 Ω	RRXAJB5Z0471
R562	CHIP RES.(1608) 1/10W J 2.7k Ω	RRXAJB5Z0272
R563	CHIP RES.(1608) 1/10W J 22k Ω	RRXAJB5Z0223
R564	CHIP RES.(1608) 1/10W J 56k Ω	RRXAJB5Z0563
R566	CARBON RES. 1/4W J 3.3 Ω or CARBON RES. 1/6W J 3.3 Ω	RCX4JATZ03R3 RCX6JATZ03R3
R567	CARBON RES. 1/4W J 3.3 Ω or CARBON RES. 1/6W J 3.3 Ω	RCX4JATZ03R3 RCX6JATZ03R3
R569▲	CHIP RES.(1608) 1/10W J 6.8k Ω	RRXAJB5Z0682
R571▲	METAL OXIDE FILM RES. 2W J 1.5k Ω or ▲ METAL OXIDE FILM RES. 2W J 1.5k Ω	RN02152ZU001 RN02152DP004
R572▲	METAL OXIDE FILM RES. 2W J 470 Ω or ▲ METAL OXIDE FILM RES. 2W J 470 Ω	RN02471ZU001 RN02471DP004
R575▲	CARBON RES. 1/4W J 15 Ω or ▲ CARBON RES. 1/6W J 15 Ω	RCX4JATZ0150 RCX6JATZ0150
R576▲	CARBON RES. 1/4W J 15 Ω or ▲ CARBON RES. 1/6W J 15 Ω	RCX4JATZ0150 RCX6JATZ0150
R577▲	CARBON RES. 1/4W J 15 Ω or ▲ CARBON RES. 1/6W J 15 Ω	RCX4JATZ0150 RCX6JATZ0150
R578	CARBON RES. 1/4W J 560 Ω or CARBON RES. 1/6W J 560 Ω	RCX4JATZ0561 RCX6JATZ0561
R579	CARBON RES. 1/4W J 1k Ω or CARBON RES. 1/6W J 1k Ω	RCX4JATZ0102 RCX6JATZ0102
R581	PCB JUMPER D0.6-P5.0	JW5.0T
R583▲	METAL OXIDE FILM RES. 2W J 2.7 Ω or ▲ METAL OXIDE RESISTOR 2W 2.7 Ω(J)	RN02JZLZ02R7 RN02JZPZ02R7
R584▲	CARBON RES. 1/4W J 1k Ω or ▲ CARBON RES. 1/6W J 1k Ω	RCX4JATZ0102 RCX6JATZ0102
R588▲	CARBON RES. 1/4W J 100k Ω or ▲ CARBON RES. 1/6W J 100k Ω	RCX4JATZ0104 RCX6JATZ0104
R589	CARBON RES. 1/4W J 100k Ω or CARBON RES. 1/6W J 100k Ω	RCX4JATZ0104 RCX6JATZ0104
R591▲	CHIP RES.(1608) 1/10W J 180k Ω	RRXAJB5Z0184
R592▲	CHIP RES.(1608) 1/10W J 100k Ω	RRXAJB5Z0104
R593▲	CHIP RES.(1608) 1/10W J 68k Ω	RRXAJB5Z0683
R594▲	CHIP RES.(1608) 1/10W J 100k Ω	RRXAJB5Z0104
R596	CHIP RES.(1608) 1/10W J 100 Ω	RRXAJB5Z0101
R597	CARBON RES. 1/4W J 8.2k Ω or CARBON RES. 1/6W J 8.2k Ω	RCX4JATZ0822 RCX6JATZ0822
R598▲	CARBON RES. 1/4W J 47k Ω or	RCX4JATZ0473

Ref. No.	Description	Part No.
▲	CARBON RES. 1/6W J 47k Ω	RCX6JATZ0473
R599▲	CHIP RES.(1608) 1/10W J 22k Ω	RRXAJB5Z0223
R601▲	CEMENT RES. 5W K 1.2 Ω or ▲ CEMENT RESISTOR 5W K 1.2 Ω or	RW051R2DP005 RW051R2PG001
▲	CEMENT RESISTOR 5W J 1.2 Ω or ▲ CEMENT RES. 3W J 1.2 Ω	RW051R2Y4001 RW031R2PG007
R602	CARBON RES. 1/4W J 820k Ω or CARBON RES. 1/6W J 820k Ω	RCX4JATZ0824 RCX6JATZ0824
R603	CARBON RES. 1/4W J 820k Ω or CARBON RES. 1/6W J 820k Ω	RCX4JATZ0824 RCX6JATZ0824
R611	CARBON RES. 1/4W J 270 Ω or CARBON RES. 1/6W J 270 Ω	RCX4JATZ0271 RCX6JATZ0271
R612	CARBON RES. 1/4W J 270 Ω or CARBON RES. 1/6W J 270 Ω	RCX4JATZ0271 RCX6JATZ0271
R613▲	METAL OXIDE FILM RES. 2W J 0.33 Ω or ▲ METAL RES 2W J 0.33 Ω	RN02JZLZ0R33 RN02JZPZ0R33
R616	CARBON RES. 1/4W J 1.5k Ω or CARBON RES. 1/6W J 1.5k Ω	RCX4JATZ0152 RCX6JATZ0152
R621	CARBON RES. 1/4W J 1.2k Ω or CARBON RES. 1/6W J 1.2k Ω	RCX4JATZ0122 RCX6JATZ0122
R622	CARBON RES. 1/4W J 82 Ω or CARBON RES. 1/6W J 82 Ω	RCX4JATZ0820 RCX6JATZ0820
R624	PCB JUMPER D0.6-P5.0	JW5.0T
R653	CHIP RES.(1608) 1/10W J 15k Ω	RRXAJB5Z0153
R654▲	CARBON RES. 1/4W J 2.7k Ω or ▲ CARBON RES. 1/6W J 2.7k Ω	RCX4JATZ0272 RCX6JATZ0272
R655▲	CARBON RES. 1/4W J 1k Ω or ▲ CARBON RES. 1/6W J 1k Ω	RCX4JATZ0102 RCX6JATZ0102
R656▲	CHIP RES.(1608) 1/10W J 15k Ω	RRXAJB5Z0153
R657▲	CARBON RES. 1/4W J 15k Ω or CARBON RES. 1/6W J 15k Ω	RCX4JATZ0153 RCX6JATZ0153
R660	CARBON RES. 1/4W J 1k Ω or CARBON RES. 1/6W J 1k Ω	RCX4JATZ0102 RCX6JATZ0102
R661▲	CARBON RES. 1/4W J 220k Ω or ▲ CARBON RES. 1/6W J 220k Ω	RCX4JATZ0224 RCX6JATZ0224
R662▲	CARBON RES. 1/4W J 6.8k Ω or ▲ CARBON RES. 1/6W J 6.8k Ω	RCX4JATZ0682 RCX6JATZ0682
R664▲	CHIP RES.(1608) 1/10W J 12k Ω	RRXAJB5Z0123
R665▲	CHIP RES.(1608) 1/10W J 4.7k Ω	RRXAJB5Z0472
R666▲	METAL OXIDE FILM RES. 2W J 15k Ω or ▲ METAL OXIDE FILM RES. 2W J 15k Ω	RN02153ZU001 RN02153DP004
R667▲	PCB JUMPER D0.6-P5.0	JW5.0T
R668▲	METAL OXIDE FILM RES. 1W J 56k Ω or ▲ METAL OXIDE FILM RES. 1W J 56k Ω	RN01563ZU001 RN01563DP003
R671	CARBON RES. 1/4W J 3.3k Ω or CARBON RES. 1/6W J 3.3k Ω	RCX4JATZ0332 RCX6JATZ0332
R672	CARBON RES. 1/4W J 3.3k Ω or CARBON RES. 1/6W J 3.3k Ω	RCX4JATZ0332 RCX6JATZ0332
R673	CARBON RES. 1/4W J 100k Ω or CARBON RES. 1/6W J 100k Ω	RCX4JATZ0104 RCX6JATZ0104
R676	CARBON RES. 1/4W J 10k Ω or CARBON RES. 1/6W J 10k Ω	RCX4JATZ0103 RCX6JATZ0103
R681▲	CARBON RES. 1/4W J 12 Ω or ▲ CARBON RES. 1/6W J 12 Ω	RCX4JATZ0120 RCX6JATZ0120
R682▲	METAL OXIDE FILM RES. 1W J 33 Ω or ▲ METAL OXIDE FILM RES. 1W J 33 Ω	RN01330ZU001 RN01330DP003
R683▲	METAL OXIDE FILM RES. 1W J 39 Ω or ▲ METAL OXIDE FILM RES. 1W J 39 Ω	RN01390ZU001 RN01390DP003
R686	CARBON RES. 1/4W J 100 Ω or CARBON RES. 1/6W J 100 Ω	RCX4JATZ0101 RCX6JATZ0101
R687	CARBON RES. 1/4W J 100 Ω or	RCX4JATZ0101

Ref. No.	Description	Part No.
	CARBON RES. 1/6W J 100 Ω	RCX6JATZ0101
R691▲	CARBON RES. 1/4W J 15k Ω or	RCX4JATZ0153
▲	CARBON RES. 1/6W J 15k Ω	RCX6JATZ0153
R696	CARBON RES. 1/4W J 10 Ω or	RCX4JATZ0100
	CARBON RES. 1/6W J 10 Ω	RCX6JATZ0100
R701	CHIP RES.(1608) 1/10W J 75 Ω	RRXAJB5Z0750
R702	CHIP RES. 1/10W J 0 Ω	RRXAJB5Z0000
R711	CHIP RES.(1608) 1/10W J 47k Ω	RRXAJB5Z0473
R712	CHIP RES.(1608) 1/10W J 3.3k Ω	RRXAJB5Z0332
R801	CARBON RES. 1/2W J 100 Ω or	RCX2JZQZ0101
	CARBON RES. 1/2W J 100 Ω	RCX2JZPZ0101
R810	METAL OXIDE FILM RES. 1W J 8.2 Ω or	RN018R2ZU001
▲	METAL OXIDE FILM RES. 1W J 8.2 Ω	RN018R2DP003
R811▲	CHIP RES.(1608) 1/10W J 2.2k Ω	RRXAJB5Z0222
R812▲	CHIP RES.(1608) 1/10W J 2.2k Ω	RRXAJB5Z0222
R821	CHIP RES.(1608) 1/10W J 12k Ω	RRXAJB5Z0123
R822	CHIP RES.(1608) 1/10W J 5.6k Ω	RRXAJB5Z0562
R831	CHIP RES.(1608) 1/10W J 470k Ω	RRXAJB5Z0474
R832	CHIP RES.(1608) 1/10W J 6.8k Ω	RRXAJB5Z0682
SWITCHES		
SW101	TACT SWITCH SKQSAB or	SST0101AL038
	TACT SWITCH KSM0612B or	SST0101HH003
	TACT SWITCH SKHHAM	SST0101AL029
SW102	TACT SWITCH SKQSAB or	SST0101AL038
	TACT SWITCH KSM0612B or	SST0101HH003
	TACT SWITCH SKHHAM	SST0101AL029
SW103	TACT SWITCH SKQSAB or	SST0101AL038
	TACT SWITCH KSM0612B or	SST0101HH003
	TACT SWITCH SKHHAM	SST0101AL029
SW104	TACT SWITCH SKQSAB or	SST0101AL038
	TACT SWITCH KSM0612B or	SST0101HH003
	TACT SWITCH SKHHAM	SST0101AL029
SW105	TACT SWITCH SKQSAB or	SST0101AL038
	TACT SWITCH KSM0612B or	SST0101HH003
	TACT SWITCH SKHHAM	SST0101AL029
SW106	TACT SWITCH SKQSAB or	SST0101AL038
	TACT SWITCH KSM0612B or	SST0101HH003
	TACT SWITCH SKHHAM	SST0101AL029
MISCELLANEOUS		
AC601▲	AC CORD LA-2366 or	WAC0172LW006
▲	AC CORD WAC0172AS006 or	WAC0172AS006
▲	AC CORD WAC0172LTE01	WAC0172LTE01
B-6	HEAT SINK(PGA) L6100UZ	0EM406787
B-7	HEAT SINK(PFZ) L6100UZ	0EM406786
B-10	JACK HOLDER L9304UZ	0EM404325
B-12	CLOTH(65) L7735TR:65X10X0.5T	0EM402149
BC101	BEAD INDUCTORS FBR07HA121TB-00	LLBF00ZTU021
BC571	BEAD INDUCTORS FBA04HA600VB-00	LLBF00STU026
BC601	BEAD INDUCTORS FBR07HA121TB-00	LLBF00ZTU021
BC602	BEAD INDUCTORS FBR07HA121TB-00	LLBF00ZTU021
BC651	BEAD INDUCTORS FBR07HA121TB-00	LLBF00ZTU021
BC652	BEAD INDUCTORS FBR07HA121TB-00	LLBF00ZTU021
BC653	BEAD INDUCTORS FBR07HA121TB-00	LLBF00ZTU021
BC691	BEAD INDUCTORS FBR07HA121TB-00	LLBF00ZTU021
BC692	BEAD INDUCTORS FBR07HA121TB-00	LLBF00ZTU021
CF301	CERAMIC TRAP 4.5MHz or	FBE455PMR003
	CERAMIC TRAP 4.5MHz	FBE455PMS001
CF302	CERAMIC FILTER SF5RA4M50CF00-B0 or	FBB455PMR004
	CERAMIC FILTER 4.5MHz	FBB455PMS001
CLN301	WIRE ASSEMBLY WX1L1100-102	WX1L1100-102

Ref. No.	Description	Part No.
F601▲	FUSE 4A/125V 237 TYPE or	PAGJ20CAG402
▲	FUSE STC4A125V U/CT	PAGE20CW3402
FH601	FUSE HOLDER MSF-015 or	XH01Z00LY001
	FUSE HOLDER FH-V-03078	XH01Z00DK001
FH602	FUSE HOLDER MSF-015 or	XH01Z00LY001
	FUSE HOLDER FH-V-03078	XH01Z00DK001
GP641▲	GAP. FNR-G3.10D	FAZ000LD6005
JK701	RCA JACK 1P AV-8.4-9Y	JXRLO10RP010
JK702	RCA JACK 1P AV-8.4-9W	JXRLO10RP011
JK801	EARPHONE JACK HTJ-035-1ZEBTZ or	JYSL030GE001
	EARPHONE JACK MSJ-035-12APC or	JYSL030LY001
	EARPHONE JACK HSJ1403-01-010 or	JYSL030HD002
	EARPHONE JACK LGY6501-0600	JYSL030SR001
JS802	PCB JUMPER D0.6-P5.0	JW5.0T
L-1	SCREW , B-TIGHT M3X8 BIND HEAD+ or	GBMB3080
	SCREW , B-TIGHT M3X8 BIND HEAD+	GBMB3080
PS691▲	THERMISTOR ZPB45BL7R0A	QNZZ45BL7R0A
RCV101	REMOCON RECEIVE UNIT MIM-93M8DKL or	USESJRSUNT02
	REMOCON RECEIVE UNIT PIC-26042SR-2 or	USESJRSKK032
	REMOCON RECEIVE UNIT PIC-37042SR	USESJRSKK034
RL601▲	POWER RELAY SDT-S-112LMR or	MRNDC12QN014
▲	POWER RELAY RPEF-12-901	MRNDC12KB002
SF1	SAW FILTER SAFGP45M7VHFZM0B03	FBB456PMR006
T571▲	FLYBACK TRANSFORMER JF0501-2409 or	LTF00CPXB021
▲	FLYBACK TRANS BSC21-2602S or	LTF00CPS2027
▲	FLYBACK TRANS BSC25-0229	LTF00CPP1002
T572	HORIZONTAL DRIVE TRANS LP2-004	LTH00CPA5004
T601▲	SWITCHING TRANS KD-01743	LTT00CPKT088
TP300	PCB JUMPER D0.6-P12.5	JW12.5T
TP301	PCB JUMPER D0.6-P10.0	JW10.0T
TP601	PCB JUMPER D0.6-P10.0	JW10.0T
TU1	TUNER ENV56DB3G3 or	UTUNNTUMS009
	TUNER B8095AP	UTUNNTUSP018
VR661▲	CARBON P.O.T. 50k Ω B or	VRCB503KA011
▲	CARBON P.O.T. 50k Ω B	VRCB503HH014
X344	XTAL 3.579545 MHz	FXD355LLN003

CRT CBA

Ref. No.	Description	Part No.
	CRT CBA Consists of the following	-----
CAPACITORS		
C501	CHIP CERAMIC CAP. CH J 330pF/50V	CHD1JJBCH331
C502	CHIP CERAMIC CAP. CH J 270pF/50V	CHD1JJBCH271
C503	CHIP CERAMIC CAP. CH J 330pF/50V	CHD1JJBCH331
C504	ELECTROLYTIC CAP. 47μF/16V M or	CE1CMASTL470
	ELECTROLYTIC CAP. 47μF/16V M	CE1CMASDL470
C510	CERAMIC CAP. B K 1000pF/2KV or	CCD3DKD0B102
	CERAMIC CAP. B K 1000pF/2KV or	CCD3DKP0B102
	CERAMIC CAP. B K 1000pF/2KV	CA3D102MR030
CONNECTOR		
CN501	PIN CONNECTOR 005P-5100	JTEA001TG001
COILS		
L501	INDUCTOR 180μH-J-5FT or	LLARJCSU181
	INDUCTOR 180μH-K-5FT	LLARKDSKA181
TRANSISTORS		
Q501	TRANSISTOR 2SC2482 TPE6 or	QQSZ02SC2482
	TRANSISTOR 2SC3468(E)-AE or	QQSE02SC3468
	TRANSISTOR 2SC3468(D)-AE or	QQSD02SC3468

Ref. No.	Description	Part No.
	TRANSISTOR KTC3207	NQSZ0KTC3207
Q502	TRANSISTOR 2SC2482 TPE6 or	QQSZ02SC2482
	TRANSISTOR 2SC3468(E)-AE or	QQSE02SC3468
	TRANSISTOR 2SC3468(D)-AE or	QQSD02SC3468
	TRANSISTOR KTC3207	NQSZ0KTC3207
Q503	TRANSISTOR 2SC2482 TPE6 or	QQSZ02SC2482
	TRANSISTOR 2SC3468(E)-AE or	QQSE02SC3468
	TRANSISTOR 2SC3468(D)-AE or	QQSD02SC3468
	TRANSISTOR KTC3207	NQSZ0KTC3207
RESISTORS		
R501	METAL OXIDE FILM RES. 1W J 15k Ω or	RN01153ZU001
	METAL OXIDE FILM RES. 1W J 15k Ω	RN01153DP003
R502	METAL OXIDE FILM RES. 1W J 15k Ω or	RN01153ZU001
	METAL OXIDE FILM RES. 1W J 15k Ω	RN01153DP003
R503	METAL OXIDE FILM RES. 1W J 15k Ω or	RN01153ZU001
	METAL OXIDE FILM RES. 1W J 15k Ω	RN01153DP003
R504	CARBON RES. 1/4W J 1.5k Ω or	RCX4JATZ0152
	CARBON RES. 1/6W J 1.5k Ω	RCX6JATZ0152
R505	CARBON RES. 1/4W J 1.5k Ω or	RCX4JATZ0152
	CARBON RES. 1/6W J 1.5k Ω	RCX6JATZ0152
R506	CARBON RES. 1/4W J 1.5k Ω or	RCX4JATZ0152
	CARBON RES. 1/6W J 1.5k Ω	RCX6JATZ0152
R509	CARBON RES. 1/4W J 1.5k Ω or	RCX4JATZ0152
	CARBON RES. 1/6W J 1.5k Ω	RCX6JATZ0152
R511	CHIP RES.(1608) 1/10W J 33 Ω	RRXAJB5Z0330
R512	CHIP RES.(1608) 1/10W J 33 Ω	RRXAJB5Z0330
R513	CHIP RES.(1608) 1/10W J 33 Ω	RRXAJB5Z0330
R514	CARBON RES. 1/4W J 5.6k Ω or	RCX4JATZ0562
	CARBON RES. 1/6W J 5.6k Ω	RCX6JATZ0562
R515	CARBON RES. 1/4W J 5.6k Ω or	RCX4JATZ0562
	CARBON RES. 1/6W J 5.6k Ω	RCX6JATZ0562
R516	CARBON RES. 1/4W J 5.6k Ω or	RCX4JATZ0562
	CARBON RES. 1/6W J 5.6k Ω	RCX6JATZ0562
R517	CARBON RES. 1/4W J 470 Ω or	RCX4JATZ0471
	CARBON RES. 1/6W J 470 Ω	RCX6JATZ0471
R518	CARBON RES. 1/4W J 470 Ω or	RCX4JATZ0471
	CARBON RES. 1/6W J 470 Ω	RCX6JATZ0471
R519	CARBON RES. 1/4W J 470 Ω or	RCX4JATZ0471
	CARBON RES. 1/6W J 470 Ω	RCX6JATZ0471
R537	CARBON RES. 1/4W J 1.5k Ω or	RCX4JATZ0152
	CARBON RES. 1/6W J 1.5k Ω	RCX6JATZ0152
R538	CARBON RES. 1/4W J 1.5k Ω or	RCX4JATZ0152
	CARBON RES. 1/6W J 1.5k Ω	RCX6JATZ0152
MISCELLANEOUS		
BC501	BEAD INDUCTORS FBR07HA121TB-00	LLBF00ZTU021
CLN501	PARALLEL WIRE 3P	WX1L1114-101
JK501 	CRT SOCKET ISMS02S	JSCC220PK003

6419CTC

L6102CC